

PLEASE RETAIN

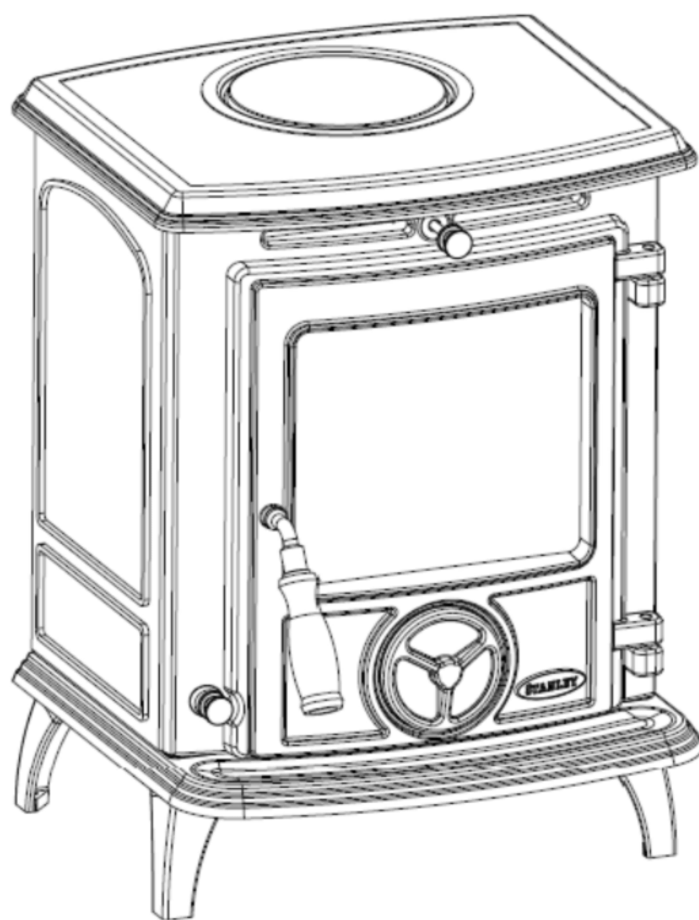

Oisin Eco v2 Solid Fuel Stove



This appliance is hot while in operation and retains its heat for a long period of time after use. Children, aged or infirm persons should be supervised at all times and should not be allowed to touch the hot working surfaces while in use or until the appliance has thoroughly cooled.

When using the boiler stove in situations where children, aged and/or infirm persons are present a fireguard must be used to prevent accidental contact with the stove. The fireguard should be manufactured in accordance with BS 8423:2010.

INSTALLATION AND OPERATING INSTRUCTIONS

TABLE OF CONTENTS

	PAGE NO.
1. Stanley Solid Fuel Stove Warranty	4
2. Installation Checklist	5
3. Important Operation/ Maintenance Notes	6
4. Installation & Operating Instructions	7
5. General	7
6. Pre-Installation Assembly	7
7. Flues	7
8. Chimney	8
9. Flue Exit - Top and Rear	8
10. Recommended flue terminal position	8
11. Ventilation and Combustion Air Regulations	9
12. External Ducted Air	10
13. Location	10
14. Clearance to Combustibles	11
15. Floor Protection	11
16. Dhw Boiler	11
17. Commissioning and Handover	11
18. Recommended Fuels	11
19. Stove Dimensions	12
20. Technical Data	12
21. Energy Labelling Fiche Details	12
22. Air Controls	13
23. Lighting	13
24. User Instructions	13
25. Refuelling	14
26. Slow Burning	14
27. De-Ashing	14
28. Disposal of Ashes	14
28. Monthly Maintenance	14
29. Periodic Maintenance	14
30. Chimney Cleaning	14
31. Glass Cleaning	15
32. Vitreous Enamel Cleaning	15
33. Cleaning a Matt Black/ Senotherm Stove	15
34. Change Rope Seals	15
35. Prolonged Periods of Non Use	15
36. Fire Safety	16
37. Glass Replacement	16
38. CO Alarm	16
39. Exploded View	17
40. Energy Label	18

THE CLEAN AIR ACT 1993 AND SMOKE CONTROL AREAS

Under the Clean Air Act local authorities may declare the whole or part of the district of the authority to be a smoke control area. It is an offence to emit smoke from a chimney of a building, from a furnace or from any fixed boiler if located in a designated smoke control area. It is also an offence to acquire an "unauthorised fuel" for use within a smoke control area unless it is used in an "exempt" appliance ("exempted" from the controls which generally apply in the smoke control area).

In England appliances are exempted by publication on a list by the Secretary of State in accordance with changes made to sections 20 and 21 of the Clean Air Act 1993 by section 15 of the Deregulation Act 2015. Similarly in Scotland appliances are exempted by publication on a list by Scottish Ministers under section 50 of the Regulatory Reform (Scotland) Act 2014.

In Wales and Northern Ireland these are authorised by regulations made by Welsh Ministers and by the Department of the Environment Respectively

Further information on the requirements of the Clean Air Act can be found here:

<https://www.gov.uk/smoke-control-area-rules>

Your local authority is responsible for implementing the Clean Air Act 1993 including designation and supervision of smoke control areas and you can contact them for details of Clean Air Act requirements.

The Oisin Solid fuel non boiler Eco stove has been recommended as suitable for use in smoke control areas when burning wood logs. A bolt has been added to the underside of the window wash air casting limiting the ability to close off the window wash air supply, if you wish to burn wood logs in a smoke control area this bolt must not be removed.

When installing, operating and maintaining your Oisin Solid fuel non boiler Eco stove respect basic standards of fire safety. Read these instructions carefully before commencing the installation. Failure to do so may result in damage to persons and property. Consult your local Municipal office and your insurance representative to determine what regulations are in force. Save these instructions for future reference.

NON SMOKE CONTROL AREAS

For areas where smoke control restrictions are not applicable, the air control can be amended to allow full closure of the window wash air control.

Option 1

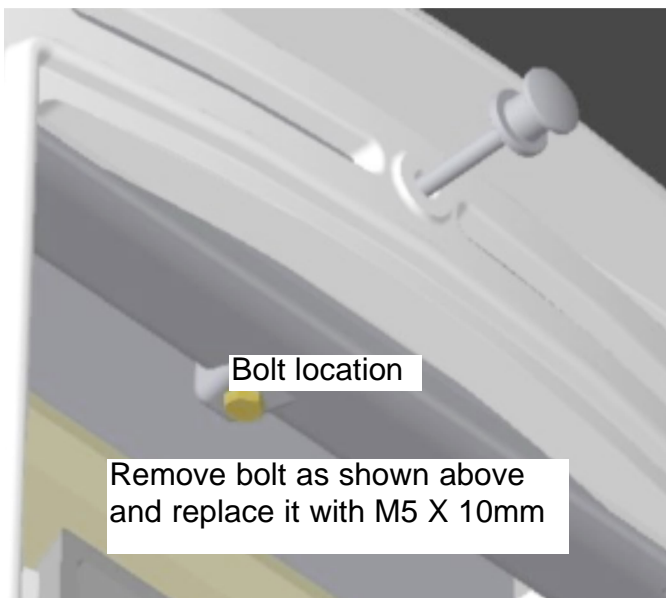

Option 2

In option 2 the method to restrict closure for smoke exempt areas has been relocated. There are two allen head screws as shown below, simply remove the screws to allow full closure. Access to the screws is through the slots on the front of the appliance over the door.

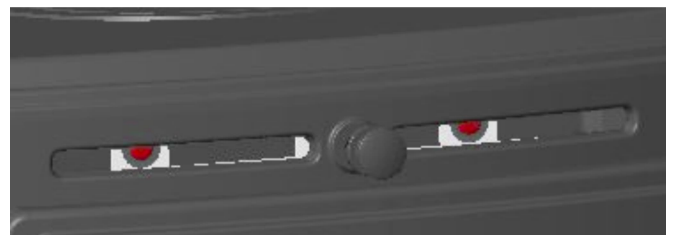



STANLEY SOLID FUEL STOVE WARRANTY

CONDITIONS OF WARRANTY

Your Stanley Solid Fuel Stove is guaranteed against any part that fails (under normal operating conditions) as detailed in the following table with timelines specified from the date of installation of the appliance. If the unit is not installed within six months of date of purchase, the warranty will commence six months from the date of purchase.

Warranty Period	Parts Covered (Parts & Labour unless Stated)
Up to 1 Year	<ul style="list-style-type: none"> • Refractory materials (supply only) • Rope seals, glass seals and cement seals. • Surface Finish on Seno models. • Grates and fire bars. • Ceramic glass is covered for Thermal breakage (supply only). • Rust (if reported before installation) • Aesthetic Damage (provided reported on date of receipt)
Up to 5 Years	<ul style="list-style-type: none"> • All external castings & enamel finishes (excluding impact damage or damage caused by overfiring). Pictures of damage must be submitted to WS Service Department.
Up to 3 Years	<ul style="list-style-type: none"> • Boiler - A Leaking Boiler Report must be conducted by an Authorised Stanley Service Engineer and submitted to WS Service Department for review.

All warranty claims must be reported to the Waterford Stanley Service Department and must be submitted with the product serial number (located on the front casting), date of purchase, proof of purchase (if requested) and details of the specific nature of the problem.

The warranty is given only to the original consumer/purchaser only and is non-transferable. The appliance must be installed by a suitable qualified person and installed as per the requirements of the manual. Failure to comply with the Installation requirements or Building Regulations will void your warranty. Waterford Stanley reserve the right to replace any part due to manufacturing defect that fails within the warranty period under the terms of the warranty. The unit must be used for normal domestic purposes only and in accordance with manufacturer's operation instructions.

LIMITS OF LIABILITY

The warranty does not cover:

- * Special, incidental or consequential damages, injury to persons or Property, or any other consequential loss.
- * Any issue caused by negligence, misuse, abuse or circumstances beyond Waterford Stanley's control.
- * Any issue with wear and tear, modification, alteration, or servicing by anyone other than an authorized service engineer.
- * Installation and operational related problems such as draught related issues external to the stove, inadequate venting or ventilation, excessive flue offsets, negative air pressure caused by insufficient burning of improper fuel.
- * Damage caused to the unit while in transit.
- * Enamel discolouration due to over firing, enamel damage caused by impact, damage to baffles caused by over firing and fading of surface finish on casting.
- * Stress fractures on bricks.
- * Rust on cast iron parts unless reported prior to unit being installed.
- * Aesthetic damage, rust & missing parts on units purchased off display.

Note: Adequate clearance must be maintained around the appliance to ensure the ease of part removal in the possible event of their damage/failure. Waterford Stanley are not responsible for any costs incurred in the removal of items installed in the vicinity of the appliance that have to be moved to facilitate a part replacement.

INSTALLATION CHECK LIST

Tick

Flue System

1. Minimum Flue Height of 4.6 metres (15 feet).
2. Appliance should be connected to a minimum of 1.8 metres (6 feet) of 150mm (6") flue pipe.
3. The horizontal flue run should not exceed 150mm (6")
4. All flue pipework passing through walls must be sleeved & adequately insulated in line with current Building Regulations.
5. Appliance should be connected to a chimney of less than 200mm (8") in diameter (otherwise the chimney must be lined with a 6" flue liner).
6. The chimney/ flue termination must be located in accordance with building regulations part J.
7. The chimney serving this appliance should not serve any other appliance.
8. Access should be provided to the chimney serving the appliance to allow for cleaning.
9. It is a requirement by Building Regulations to have a carbon monoxide alarm fitted to any room with a solid fuel appliance.

Location

10. Clearance to combustible materials must be adhered to as described in the Clearance to Combustible section.
11. The stove must be installed on a floor protector that covers the area under the stove and extends 300mm to the front & 150mm to the sides and back.
12. Clearance must be maintained to allow for maintenance and part replacement.

Ventilation & Combustion Air Requirements

13. The room in which the appliance is located should have an air vent of adequate size to support correct combustion (see Ventilation & Combustion Air Requirement Section for specific details).
14. The stove must not be installed in the same room as an extractor fan.



IMPORTANT OPERATION / MAINTENANCE NOTES

Now that your Stanley Solid Fuel Stove is installed and no doubt you are looking forward to many comforts it will provide, we would like to give you some tips on how to get the best results from your stove.

1. We would like if you could take some time to read the operating instructions/hints, which we are confident, will be of great benefit to you.
2. Do not burn fuel with a high moisture content, wood logs should have a moisture content of 20% or less.
3. **IMPORTANT:** The first few fires should be relatively small to permit the refractory to set properly and season the stove. During these firings it is recommended to ventilate the room as an unpleasant (not toxic) odour may be emitted as the paint is completing curement.
4. **Inspect the flue-ways of the stove weekly and ensure that there are no blockages. Check flue ways before lighting especially after a shut down period. Please see chimney cleaning section.**
5. Before loading fresh fuel into the firebox, riddle fully to remove all ashes. This will allow better and cleaner burning. See Re-Fuelling section.
6. Never allow a build up of ashes in the ash pan, as this will cause the grate to burn out prematurely. Empty the ashpan when refuelling.
7. Avoid slow burning of damp or unseasoned fuel as this will result in tarring flue ways and chimney i.e. peat or timber.
8. Allow adequate air ventilation to ensure plenty of air for combustion.
9. Do not burn rubbish/household plastic.
10. Do not operate the stove with the ash-door open as this will over heat the unit causing unnecessary damage.
11. Clean the chimney at least twice a year.
12. Burning soft fuels such as timber and peat will stain the glass. Regular cleaning will prevent permanent staining. Clean with soapy water when cool.
13. Keep all combustible materials a safe distance away from unit, please see section for clearances to combustibles.
14. Never use aerosol spray near the appliance when it is in operation.
15. For safety reasons never leave children or the elderly unaccompanied while stove is in use. Use a fire guard.
16. Avoid contact with the appliance when in use as stove reaches very high operating temperatures.
17. This appliance should be regularly maintained by a competent service engineer.

THE OISIN SOLID FUEL NON BOILER STOVE INSTALLATION & OPERATING INSTRUCTIONS

GENERAL

When installing, operating and maintaining your Oisin Stove respect basic standards of fire safety. Read these instructions carefully before commencing the installation. Failure to do so may result in damage to persons and property. Consult your local Municipal office and your insurance representative to determine what regulations are in force. Save these instructions for future reference.

Please note that it is a legal requirement under England & Wales Building Regulations that the installation of the stove is either carried out under Local Authority Building Control approval or is installed by a Competent Person registered with a Government approved Competent Persons Scheme. HETAS Ltd operate such a scheme and a listing of their Registered Competent Persons can be found on their website at www.hetas.co.uk.

Special care must be taken when installing the stove such that the requirements of the Health & Safety at Work Act are met.

Handling

Adequate facilities must be available for loading, unloading and site handling.

Fire Cement

Some types of fire cement are caustic and should not be allowed to come into contact with the skin. In case of contact with the skin wash immediately with plenty of water.

Asbestos

This stove contains no asbestos. If there is a possibility of disturbing any asbestos in the course of installation then please seek guidance and use appropriate protective equipment.

Metal Parts

When installing or servicing this stove care should be taken to avoid the possibility of personal injury.

“IMPORTANT WARNING”

This stove must not be installed into a chimney that serves any other heating appliance.

The complete installation must be done in accordance with current Standards and Local Codes. It should be noted that the requirements and these publications may be superseded during the life of this manual.

Please refer to the current standards, BS EN 15287-1:2007 Design, Installation and Commissioning of chimneys.

Your Oisin stove is supplied with the following items:

- Bakelite Handle (attached to front of stove)
- Legs
- Glove
- Ashpan
- Operating Tool
- Installation & Operating Manual
- M8 bolts x 2 , (can be fitted in outside holes at rear if burning wood only)
- M5 x10mm bolt (as per non smoke control areas page 3)

PRE-INSTALLATION ASSEMBLY

1. Remove the box from the stove while leaving the stove on the pallet.
2. Carefully tilt the stove back and fit the legs to the front of the stove. Leg bolts are fitted to the base, if necessary slide the stove forward so that it overhands the pallet.
3. Carefully tilt the stove forward and fit the legs to the rear of the stove.
4. Remove the stove from the pallet and position it in the final installation position (see location and clearance to combustibles section).

FLUES

Flues should be vertical wherever possible and where a bend is necessary, it should not make an angle of more than 45° with the vertical. Horizontal flue runs should be avoided except in the case of a back outlet from the appliance, when the length of

CHIMNEY

The Oisin must be connected to a chimney of the proper size and type. The chimney must have a diameter of at least 150mm. Never connect to a smaller size chimney. Do not connect to a chimney serving another appliance. The stove is supplied with a 5" flue spigot, the flue installation will require a 5" to 6" increaser which must be fitted within 1.5 meters of flue outlet. Minimum chimney height 15' (4.6 meters) from floor on which stove is installed. A flue that has proved to be unsatisfactory, particularly with regard to down draught should not be used for venting this appliance until it has been examined and any faults corrected. An existing masonry chimney should be inspected and if necessary repaired by a competent mason or relined using an approved lining system. The stove must be connected to a chimney with a minimum continuous draught of 0.06 w.g. Poor draught conditions will result in poor performance.

All register plates, restricter plates, damper etc., which could obstruct the flue at a future date should be removed before connecting this appliance. If connecting to an existing chimney with a flue diameter of more than 8" it is recommended to line the flue using a suitable stainless steel flue liner.

FLUE EXIT (TOP & REAR)

Fig.2

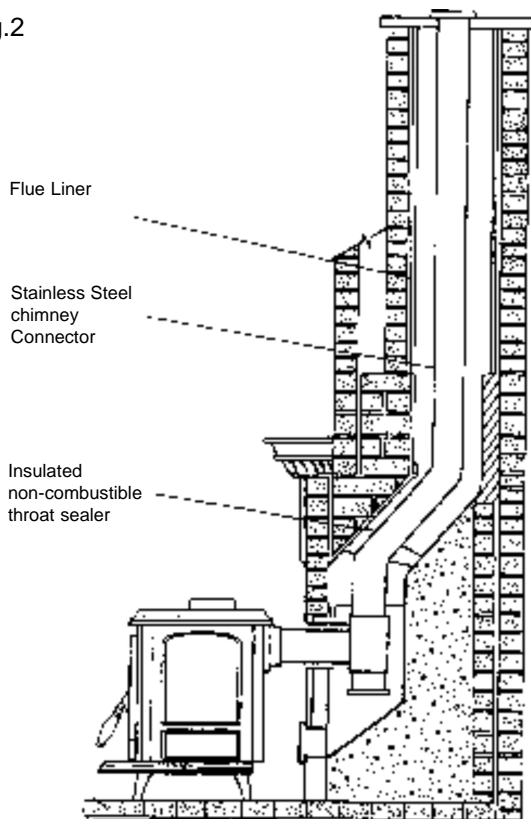

TOP FLUE EXIT

For the top outlet configuration, remove the blanking plate from the hob, remove the flue spigot from the back plate and fix it to the hob. Fix the outlet blanking plate to back plate (see Fig. 3). Push the flue outlet connector pipe (not supplied) into the flue spigot and cement into place using approved fire cement ensuring that no cement blocks the flue passageway.

Fig.3

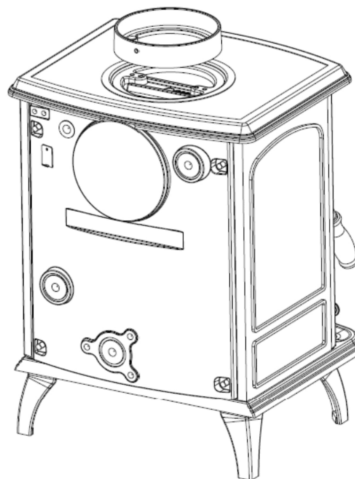

REAR FLUE EXIT

Push the flue connector pipe (not supplied) into the flue spigot and cement into place using approved fire cement ensuring that no cement blocks the flue passageway (see Fig.4).

Fig.4

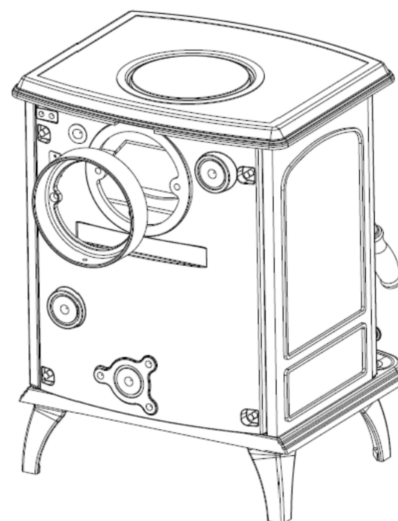

To minimise the wind effects, the flue termination point should be located in accordance with building regulation part J (See Fig.5), Where this termination point does not suffice it may be necessary to extend the flue pipe so that the termination point is above the apex. For further information please refer to building regulations part J.

Outlets from flues for solid fuel burning appliances

Outlet of a chimney or a flue to be not less than 1m above the highest point of contact of chimney and roof. Where the roof has a pitch of more than 10° on both sides and the outlet is at the ridge or within 600 mm of it, the height of the chimney or flue pipe may be reduced to 600 mm.

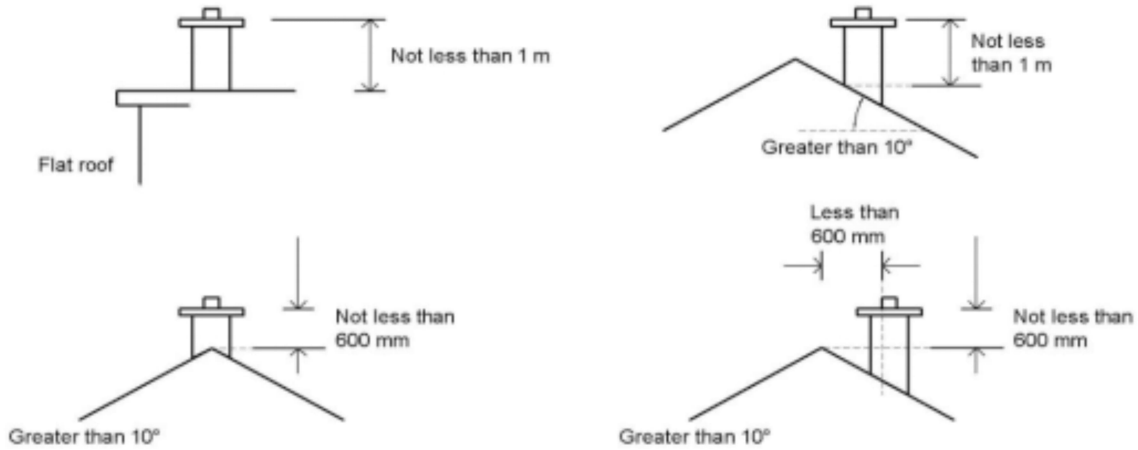

(a) HEIGHT OF FLUE OVER ROOF

The outlet of a chimney or flue pipe should also be not less than 1m above the top of any opening skylight, opening window or wall ventilator within 2.3 m.

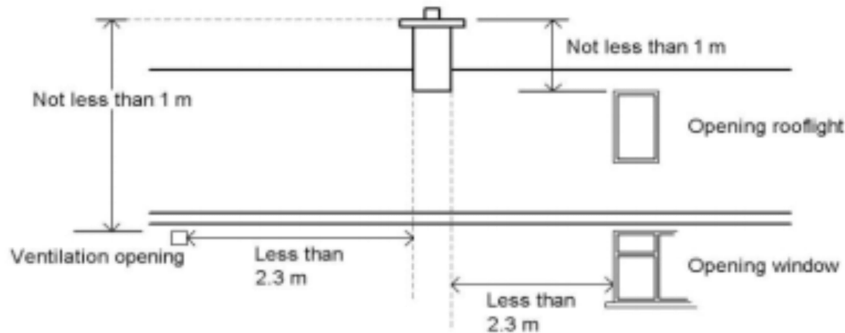

(b) HEIGHT OF FLUE OVER OPENINGS

The outlet of a chimney or flue pipe in relation to adjacent or adjoining buildings should be as shown below.

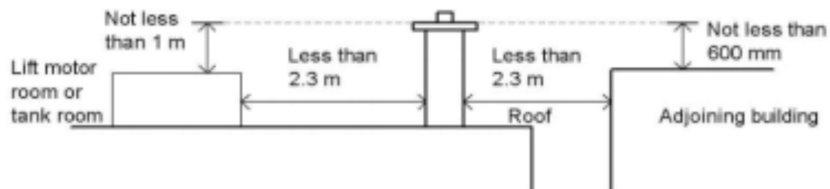

(c) HEIGHT OF FLUE OVER ADJACENT OR ADJOINING BUILDING

VENTILATION & COMBUSTION AIR REQUIREMENTS

It is imperative that there is sufficient air supply to the stove in order to support correct combustion. The air supply to this appliance must comply with current Building Regulations Part J, Heat Providing Appliances. If another appliance is fitted in an adjacent room it will be necessary to calculate an additional air supply.

All materials used in the manufacture of air vents should be such that the vent is dimensionally stable, corrosion resistant, and no provision for closure. The effective free area of any vent should be ascertained before installation. The effect of any grills should be allowed for when determining the effective free area of any vent.

Air vents should be positioned so that they are not liable to blockage.

Air vents direct to the outside of the building should be located so that any air current produced will not pass through normally occupied areas of the room.

An air vent outside the building should not be located less than the dimensions specified within the Building Regulations and B.S. 8303: Part 1 from any part of any flue terminal. These air vents must also be satisfactorily fire proofed as per Building Regulations and B.S. 8303: Part 1.

Air vents in internal walls should not communicate with bedrooms, bedsits, toilets, bathrooms or rooms containing a shower.

Air vents traversing cavity walls should include a continuous duct across the cavity. The duct should be installed in such a manner as not to impair the

Joints between air vents and outside walls should be sealed to prevent the ingress of moisture. Existing air vents should be of the correct size and unobstructed for the appliance in use.

If there is an extraction fan fitted in adjacent rooms where this appliance is fitted, additional air vents may be required to alleviate the possibility of spillage of products of combustion from the appliance/flue while the fan is in operation. Refer to B.S. 8303 Part 1.

Note:

There must not be an extractor fan fitted in the same room as the stove as this can cause the stove to emit smoke and fumes into the room.

Especially Airtight Properties:-

If the stove is being fitted in a property where the design air permeability is less than $5\text{m}^3 / (\text{h.m}^2)$ (normally newer properties built from 2006), then a permanent ventilation must be fitted to provide 550mm^2 of ventilation for each kW of rated output. If a draught stabiliser is also fitted then the requirement is 850mm^2 per kW of rated output.

EXTERNAL DUCTED AIR

As the Oisin Eco takes secondary air from the room through the air inlets over the door the product is not recommended for use with external ducted air.

COMMISSIONING & HANDOVER

On completion of the installation allow a suitable period of time for any fire cement and mortar to dry out, when a small fire may be lit and checked to ensure the smoke and fumes are taken from the stove up the chimney and emitted safely to the atmosphere. **Do not run at full output for at least 24 hours.**

On completion of the installation and commissioning ensure that the operating instructions for the stove are left with the customer. Ensure to advise the customer on the correct use of the appliance with the fuels likely to be used on the stove and warn them to use only the recommended fuels for the stove.

Advise the user what to do should smoke or fumes be emitted from the stove. The customer should be warned to use a fire guard to BS 8423:2002 in the

LOCATION

There are several conditions to be considered in selecting a location for your Stanley Oisin Stove.

- a. Position in the area to be heated, central locations are usually best.
- b. Allowances for proper clearances to combustibles.
- c. Allowances for proper clearances for maintenance work.

CLEARANCE TO COMBUSTIBLES

Maintain at least the following clearances to all combustible material:

Side wall to stove	550mm
Back wall to stove	550mm
Corner	390mm
Mantle clearance	635mm

CLEARANCE TO COMBUSTIBLES

It is recommended that this appliance is sited next to and on a non-combustible surface. A minimum all round clearance of 100mm will allow air circulation and not impede the performance of the stove. If it is necessary to site the stove near to a combustible surface a minimum clearance of 475mm to side walls and 550mm to rear walls must be maintained. The connector may pass through walls or partitions constructed of combustible materials provided the connector is either listed for wall pass-through or is routed through a device listed for a wall pass-through and is installed in accordance with the conditions of the listing. Any unexposed metal that is used as part of a wall pass-through system is exposed to flue gases shall be constructed of stainless steel or other equivalent material that will resist corrosion, softening, or cracking from flue gas at temperatures up to 982°C.

FLOOR PROTECTION

It is recommended that this appliance is installed on a solid, level, non combustible hearth conforming to current Building Regulations part J heat producing appliances.

When installing this heater on a combustible floor, a floor protector, consisting of a layer of non-combustible material at least 12mm thick is required to cover the area under the heater and extend to at least 300mm at the front and 150mm to the sides and rear.

DHW Boiler.

The Oisin Eco is not recommended for use with the dhw boiler that was previously used on Oisin stoves.

COMMISSIONING & HANDOVER

On completion of the installation allow a suitable period of time for any fire cement and mortar to dry out, when a small fire may be lit and checked to ensure the smoke and fumes are taken from the stove up the chimney and emitted safely to the atmosphere. **Do not run at full output for at least 24 hours.**

Ensure that the operating instructions for the stove are left with the customer. Ensure to advise the customer on the correct use of the appliance with the fuels likely to be used on the stove and warn them to use only the recommended fuels for the stove.

Advise the user what to do should smoke or fumes be emitted from the stove. The customer should be warned to use a fire guard to BS 8432: 2010 in the presence of children, aged and/or infirm persons.

RECOMMENDED FUELS

All fuels should be stored under cover and kept as dry as possible prior to use.

This appliance has been tested using seasoned wood logs and manufactured briquetted smokeless fuel (Ancit) for closed appliances, sized between 20g and 140g. Other fuels are commercially available and may give similar results. Wood logs with a moisture content of 20% or less and up to 240mm long are suitable. All fuels should be stored under cover and kept as dry as possible prior to use.

Do not use fuels with a Petro-coke ingredient as this may cause the grate to overheat, causing damage. Reduced outputs will result when fuels of lower calorific values are used. Never use gasoline or gasoline type lantern fuel, kerosene, charcoal lighter fluid or similar liquids to start or freshen up a fire in this heater. Keep all such liquid well away from the heater at all times. Operate the stove only with the fuelling door closed except for re-fuelling.

This stove has obtained HETAS Ltd approval for burning natural and manufactured smokeless fuels only as detailed in recommended fuels below. HETAS Approval does not cover the use of other fuels either alone or mixed with the recommended fuels listed, nor does it cover instructions for the use of other fuels.

WARNING: DO NOT OBSTRUCT THE PRIMARY AIR SUPPLY TO THE SPIN VALVE AT THE FRONT OF THE STOVE.

STOVE DIMENSIONS

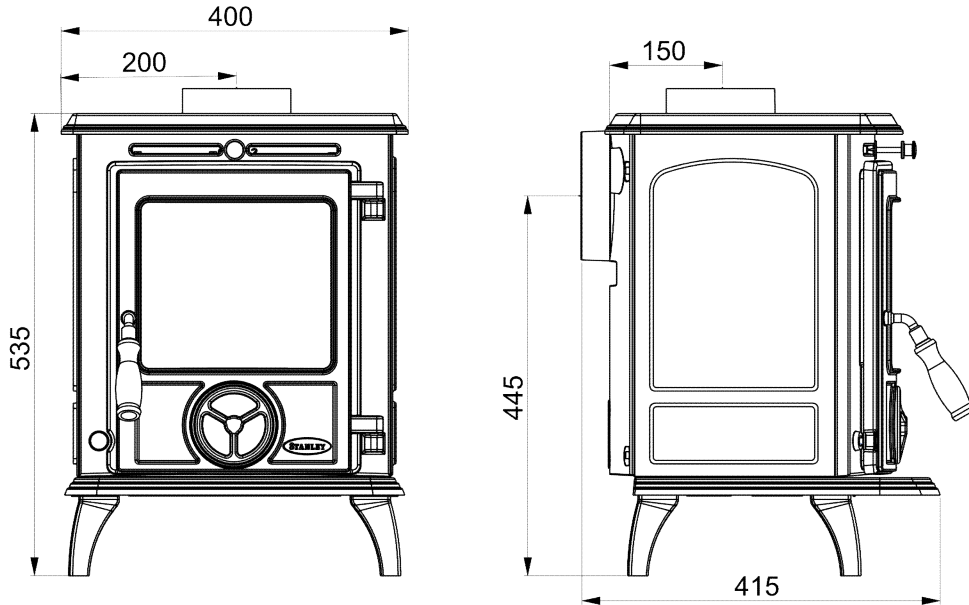

Note: Dimensions stated are in millimetres and may be subject to a slight +/- variation.

TECHNICAL DATA

Parameter	Units	Smokeless Mineral Fuel	Wood
Typical refuel interval - nominal outputs:	h	1.05	0.83
Total efficiency	%	81.5	81.4
Nominal heat output	kW	5.0	5.0
Mean CO emission (at 13 % O ₂)	%	0.07	0.09
Mean flue gas temperature	°C	270	257
Flue gas mass flow	g/s	3.6	4.3
Mean CnHm emission (at 13 % O ₂)	Nmg/m ³	37	73
Mean NO _x emission (at 13 % O ₂)	Nmg/m ³	100	95
DIN Plus particulates (at 13 % O ₂)	Nmg/m ³	19	12
Flue outlet Diameter	mm	125	
Flue Draught	Pa	12	
Weight	kg	72	
Log size:	mm	NA	240

ENERGY LABELLING FICHE DETAILS

Model	Energy Efficiency Class	Heat Output to Room	Heat Output to Water	Energy Efficiency Index	Preferred Fuel	Nominal Heat Output	Net Efficiency
Oisín NB SF Stove	A+	5.0	N/A	109	Wood	5.1	81.4

AIR CONTROLS Primary air control

The spin valve, located in the door, controls the primary air supply to the stove. For maximum heat output and burn rate on smokeless coal rotate the spin valve fully in an anti-clockwise direction and for a minimum heat output and burn rate rotate the spin valve clockwise until fully closed. (See Fig.6)

Note:

The controls may become hot when the stove is in operation, use tool or glove provided to adjust the controls when the stove is hot. The door handle is supplied with a spigot and should not be left in place while the stove is in use.

Fig.6

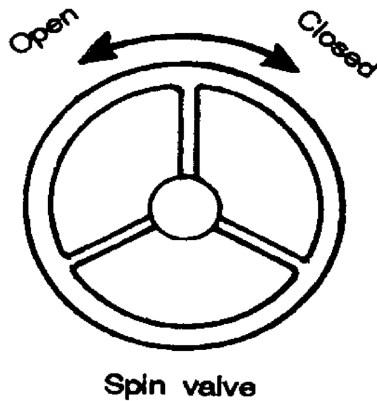

Secondary air control

The secondary air control is located over the door, this controls the secondary air / window wash air-supply to the stove. For maximum heat output and burn rate on wood pull the control knob out fully, for a minimum heat output and burn rate push the knob in fully to close off the air supply. (See Fig.7)

Fig.7

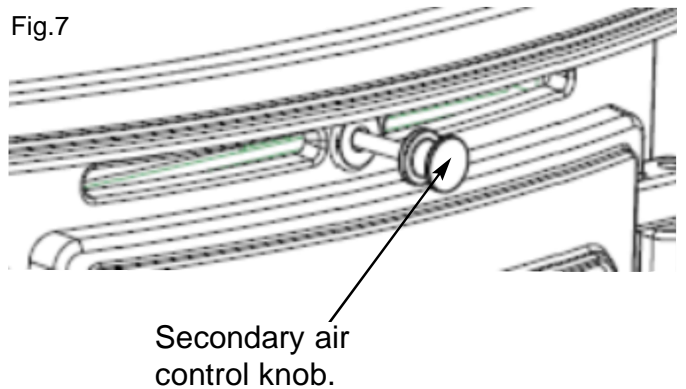

AIR CONTROLS				
Fuel	Ignition		Controlled Burn	
	Primary	Secondary	Primary	Secondary
Mineral smokeless fuel (Maxibrite)	Fully Open	Fully Open	0-80% Open	Fully Closed
Wood	Fully Open	Fully Open	0-10% Open	0-80% Open

LIGHTING

Before lighting the stove check with the installer that the installation work and commissioning checks described previously have been carried out correctly and that the chimney has been swept clean, is sound and free from any obstructions. As part of the stoves commissioning and handover the installer should demonstrate how to operate the stove correctly.

USER INSTRUCTIONS

1. Before lighting the stove, ensure that any build-up in the firebox has been removed and that the ashpan has been emptied.
2. Open the air controls.
3. Lay a few crumpled sheets of paper on the hearth and then a few small sticks, kindling or an approved firelighter.
4. Ignite and close the door.
5. **Never use inflammable liquid i.e. gasoline, petrol paraffin etc. to start or “freshen up” a fire in this heater.**
6. When the fire is well established , fuel the stove and adjust the air controls to the required setting.
7. The appliance must not be operated with the door left open except as directed in the instructions, operation with teh door left open can cause excessive smoke
8. Operation with the air controls fully open can cause excessive smoke, the appliance controls must be shut down in accordance with teh table above after the ignition period to prevent excessive smoke.

RE-FUELLING ON TO A LOW FIREBED

If there is insufficient burning material in the firebed to light a new fuel charge, excessive smoke can occur. Refueling must be carried out on to a sufficient quantity of glowing embers that will allow the new fuel charge ignite in a reasonable period. If there are too few glowing embers in the fire bed add suitable kindling to prevent excessive smoke.

Riddle the fire by connecting the grate operating tool onto the riddling knob located at the bottom front of the stove, then gently pull and push the riddling knob until all dead ash has fallen through into the ashpan. Before opening the door, open the spin valve by turning it anti-clockwise, as this will help to eliminate any smoke or fly ash resident in the combustion chamber. Add fuel to fire, close fire door and re-set spin valve to required setting after flame has established. (See Fig.8)

FUEL OVERLOADING

For smoke control areas the maximum fuel load of 1.2 kg of seasoned wood logs must not be exceeded. Overloading can cause excess smoke.

Fig.8

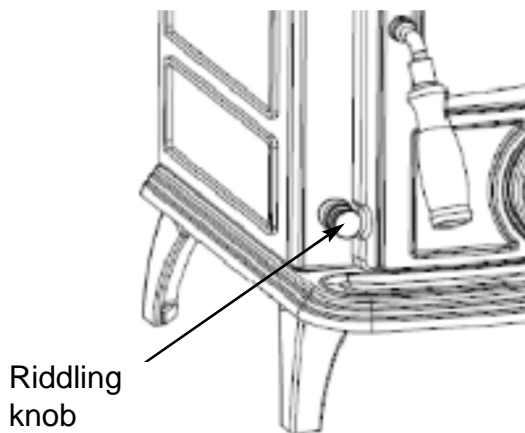

SLOW BURNING

Slow burning will cause the window glass to blacken and should not be used for a long period. Opening the air controls will increase the heat output and should remove most of the soot deposits from the glass. For slow burning setting open the spin valve so that it is approx 1/4 turn open. Slow burning is not possible on smoke exempted appliances and is not generally recommended as it produces excessive smoke.

DE-ASHING

Never allow ashpan to over fill as it will cause damage to firebars. Open the fire door and remove ashpan using the operating tool. Close the fire door. When the ash is disposed of, replace the empty ashpan. (See Fig.9)

Fig.9

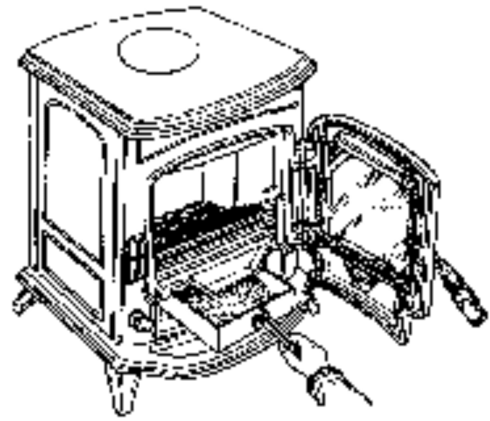

DISPOSAL OF ASH

Ashes should be placed in a metal container with a tight fitting lid. The closed container of ashes should be on a non-combustible floor or on the ground well away from all combustible materials pending final disposal. If the ashes are disposed of by burial in soil or other wise locally dispersed they should be retained in the closed container until all cinders have thoroughly cooled.

REMEMBER COAL GASES ARE TOXIC.

MONTHLY MAINTENANCE

Remove the firebars by lifting them clear of the fire fence retainers.

Vermiculite fire lining are highly resistant to temperature but are easily broken and must be handled with care.

To access the flue pathways, remove the vermiculite baffle by raising it gently on one side to make room to remove the vermiculite side brick on that side. Repeat for the opposite side and then remove the vermiculite baffle.

Then remove the steel baffle by lifting the back edge of the back brick and sliding it forward allowing the back edge drop down for ease of removal. Remove the back brick and clean the internal of the stove and all clean the baffles and bricks prior to them being refitted.

Remove the ashpan and clean the surrounding area where a build of ash may occur and impede fitting of the ashpan.

PERIODIC MAINTENANCE

CHIMNEY CLEANING

Chimney and connector should be cleaned at least twice a year. Once before heating season and once after.

The chimney connector and chimney should be inspected at least monthly during the heating season to determine if a creosote build-up has occurred. Remove the vermiculite baffle and side bricks, remove the steel baffle resting on the air box casting and the rear vermiculite brick, then remove the rear vermiculite brick before chimney cleaning.

GLASS CLEANING

The stove glass will self-clean when there is sufficient heat generated by the burning fuel i.e. when the unit is operated at the maximum air settings. If a build-up of creosote occurs on the glass it may be due to low draft conditions, poor quality fuel or operating the stove at the minimum air settings for long periods of time. The glass should be cleaned when cool and cleaned with a non-abrasive cloth using warm soapy water. For stubborn deposits, a grade 0 steel wool can be used whilst taking care not to scratch the glass with any coal/ash deposits.

VITREOUS ENAMEL CLEANING

General cleaning must be carried out when the stove is cool.

If this stove is finished in a high gloss vitreous enamel, to keep the enamel in the best condition observe the following tips:

1. Wipe over daily with a soapy damp cloth, followed by a polish with a clean dry duster.
2. For stubborn deposits a soap impregnated pad can be carefully used on the vitreous enamel.
3. Use only products recommended by the Vitreous Enamel Association, these products carry the Vitramel label.

A detailed list of the approved cleaners can be found on their website www.vea.org.uk/enamel-care/

DO NOT USE ABRASIVE PADS OR OVEN-CLEANSERS CONTAINING CITRIC ACID ON ENAMELLED SURFACES. ENSURE THAT THE CLEANSER MANUFACTURERS INSTRUCTIONS ARE ADHERED TO.

NOTE: Small impact marks on the enamel finish can be repaired using an appropriate enamel touch up (a touch up bottle is included with the stove packaging) but it should not be used to cover marks greater than $\varnothing 10\text{mm}$ or multiple marks on the same casting/area.

CLEANING A MATT BLACK/SENOTHERM STOVE

Cleaning should be done when the stove is cold by removing any dust or dirt using a dry cloth. Do not use any water on the matt black/senotherm finish as this will cause it to rust.

CHANGING THE ROPE SEALS

The rope seal between the door & the front casting will compress & harden over time and whilst small adjustments can be made to the door catch to ensure the integrity of the rope seal, it will be necessary to replace the rope seals on the stove periodically depending on stove usage. It is recommended that the rope seals are changed at least every two years.

PROLONGED PERIODS OF NON USE

If the stove is to be left unused for a prolonged period of time then it should be given a thorough clean to remove ash and unburned fuel residues. To enable a good flow of air through the appliance to reduce condensation and subsequent damage, leave the air controls fully open.

It is important that the flue connection, any appliance baffles or throat plates and the chimney are swept prior to lighting up after a prolonged shutdown period.

WARNING NOTE:

Properly installed, operated and maintained this stove will not emit fumes into the dwelling. Occasional fumes from the de-ashing and re-fuelling may occur. However, persistent fume emission is potentially dangerous and must not be tolerated. If fume emission does persist, then the following immediate action should be taken:

- (a) Open doors and windows to ventilate room.
- (b) Let the fire out or eject and safely dispose of fuel from the stove.
- (c) Check for flue or chimney blockage and clean if required.
- (d) Do not attempt to relight the fire until the cause of the fume emission has been identified and corrected. If necessary seek expert advice.

The most common cause of fume emission is flue-way or chimney blockage. For your own safety these must be kept clean at all times.

FIRE SAFETY

To provide reasonable fire safety, the following should be given serious consideration.

1. Do not over fire the stove.
2. Over-firing will also damage painted or enamel finish.
3. Install a smoke detector in the room.
4. A conveniently located class A fire extinguisher to contend with small fires resulting from burning embers.
5. A practical evacuation plan.
6. A plan to deal with a chimney fire as follows:-
 - (a) Notify the fire department.
 - (b) Prepare occupants for immediate evacuation.
 - (c) Close all openings into the stove.
 - (d) While awaiting the fire department watch for ignition to adjacent combustibles from overheated flue pipe or from embers or sparks from the chimney.

GLASS REPLACEMENT

- a. Open the door fully.
- b. Remove the four corner screws and clips and carefully remove the broken glass.
- c. Clean the glass recess in the door.
- d. Attach adhesive thermal tape to the perimeter of the replacement glass.
- e. Place the thermal tape side of the glass into the door recess and replace the four corner clips.
- f. Tighten screws.
- g. Replace glass only with ceramic glass 5mm thick. (See Fig.10)

Fig.10

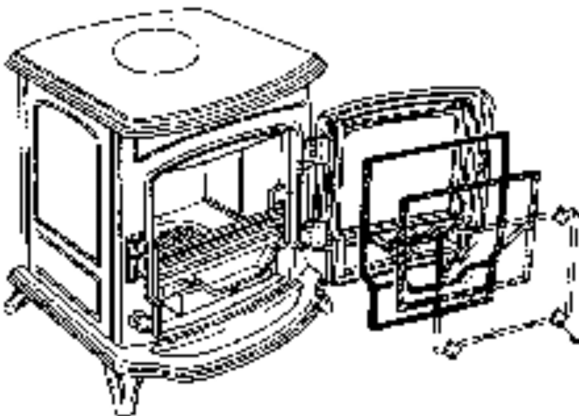

CO ALARM

The fitting of CO Alarms in the same room as the appliance is a compulsory requirement under current Building Regulations. For ROI an additional CO Alarm must be fitted either inside each bedroom or within 5 metres of the bedroom door, refer to Building Regulations Part J. Further guidance on the installation of a carbon monoxide alarm is available in BS EN 50292:2002 and from the alarm manufacturers instructions.

Provision of an alarm must not be considered a substitute for either installing the appliance correctly or ensuring regular servicing and maintenance of the appliance and chimney system.

WARNING:-

If the CO Alarm sounds unexpectedly:-

- 1. Open Doors and windows to ventilate the room and then leave the premises.**
- 2. Let the fire go out.**

OISIN SF NB ECO EXPLODED VIEW

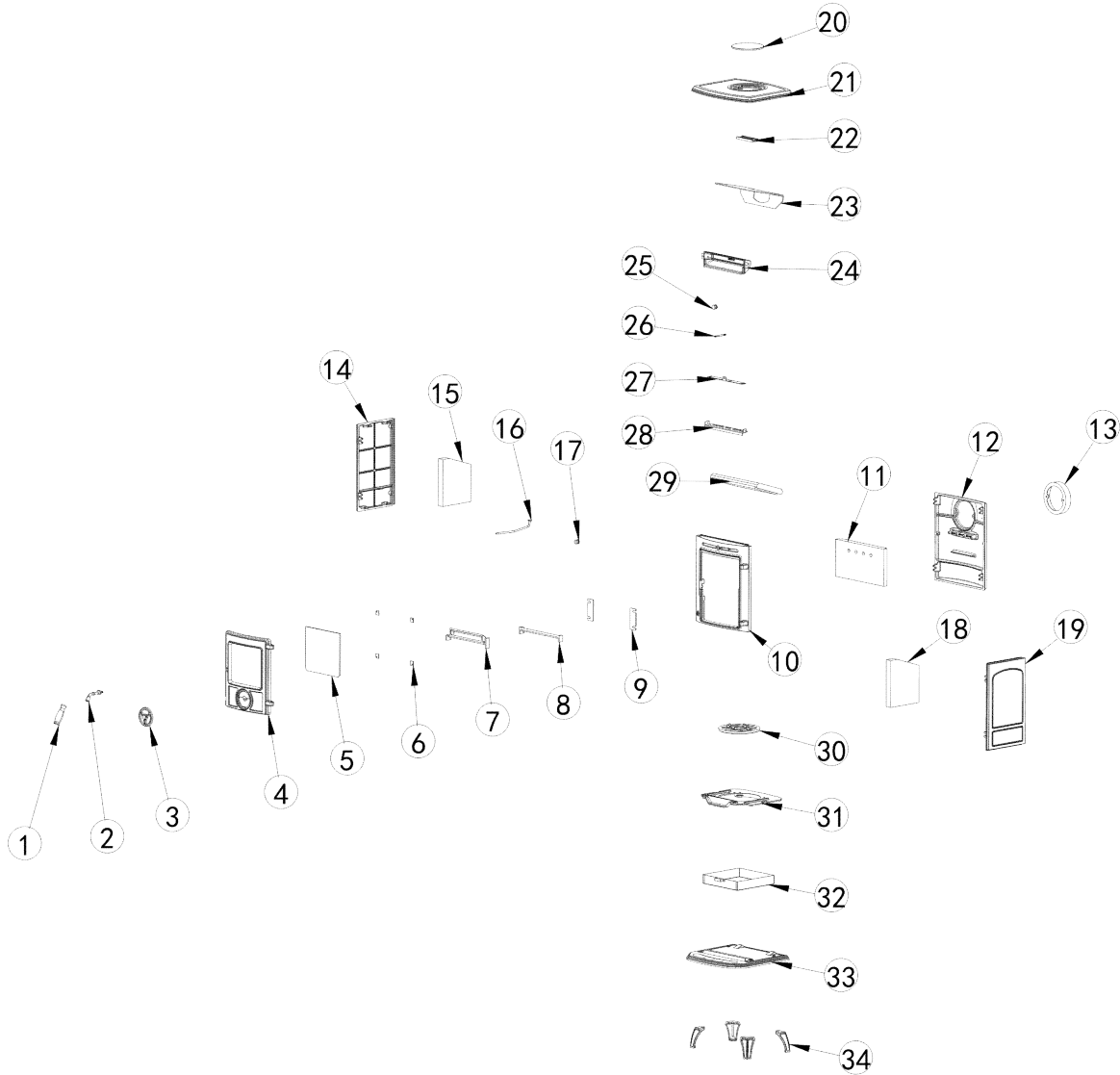

Item No.	Part name	Part code	Item No.	Part name	Part code
1	Handle	U00198AXX	19	Right Side Panel	INB00652AXX
2	Handle Axle	INF00928AXX	20	Blanking Plate	INB00006AXX
3	Spin Valve	INB00012AXX	21	Hob	INB00008BXX
4	Door	INB00580AXX	22	Brace Bracket	INQ00759AXX
5	Glass	INT00094AXX	23	Top Baffle	INF01360AXX
6	Glass Clip	F00003AXX	24	Air Box Casting	INQ00742AXX
7	Fire Fence Upper	INQ00743AXX	25	Knob	INU00165AXX
8	Fire Fence Lower	INQ00005AXX	26	Air Control Rod	INV00856AXX
9	Fire Fence Bracket	INQ00006AXX	27	Air Wash Slider Plate	INF00926AXX
10	Front Frame	INB00581AXX	28	Air Release Plate	INF00927AXX
11	Rear Brick	H00243AXX	29	Bottom Baffle Vermiculate	H00244AXX
12	Back Panel	INQ00576DXX	30	Grate	INZ00025BXX
13	Spigot	INB00007BXX	31	Grate Support Plate	Q00001BXX
14	Left Side Panel	INB00651AXX	32	Ashpan	F00001AXX
15	Left Side Brick	H00242AXX	33	Base	INB00002AXX
16	Pull Rod	INV00859AXX	34	Leg	INB00001AXX
17	Rod Knob	INU00165AXX	35	Hinge Pin	INV00867AXX
18	Right Side Brick	H00242AXX			



ENERG
енергия · ενεργεια

Y IJA
IE IA

Stanley

Oisin Eco

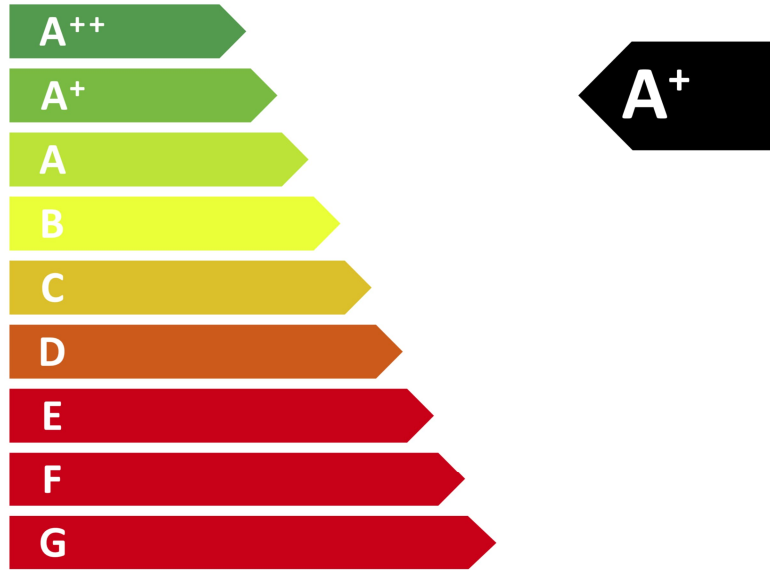

5,0
kW

ENERGIA · ЕНЕРГИЯ · ΕΝΕΡΓΕΙΑ · ENERGIJA · ENERGY · ENERGIE · ENERGI

2015/1186

NOTES

Manufactured by
Waterford Stanley Ltd.,
Unit 401-403, IDA Industrial Estate, Cork Road,
Waterford, Ireland.
Tel: (051) 302300 Fax (051) 302315