

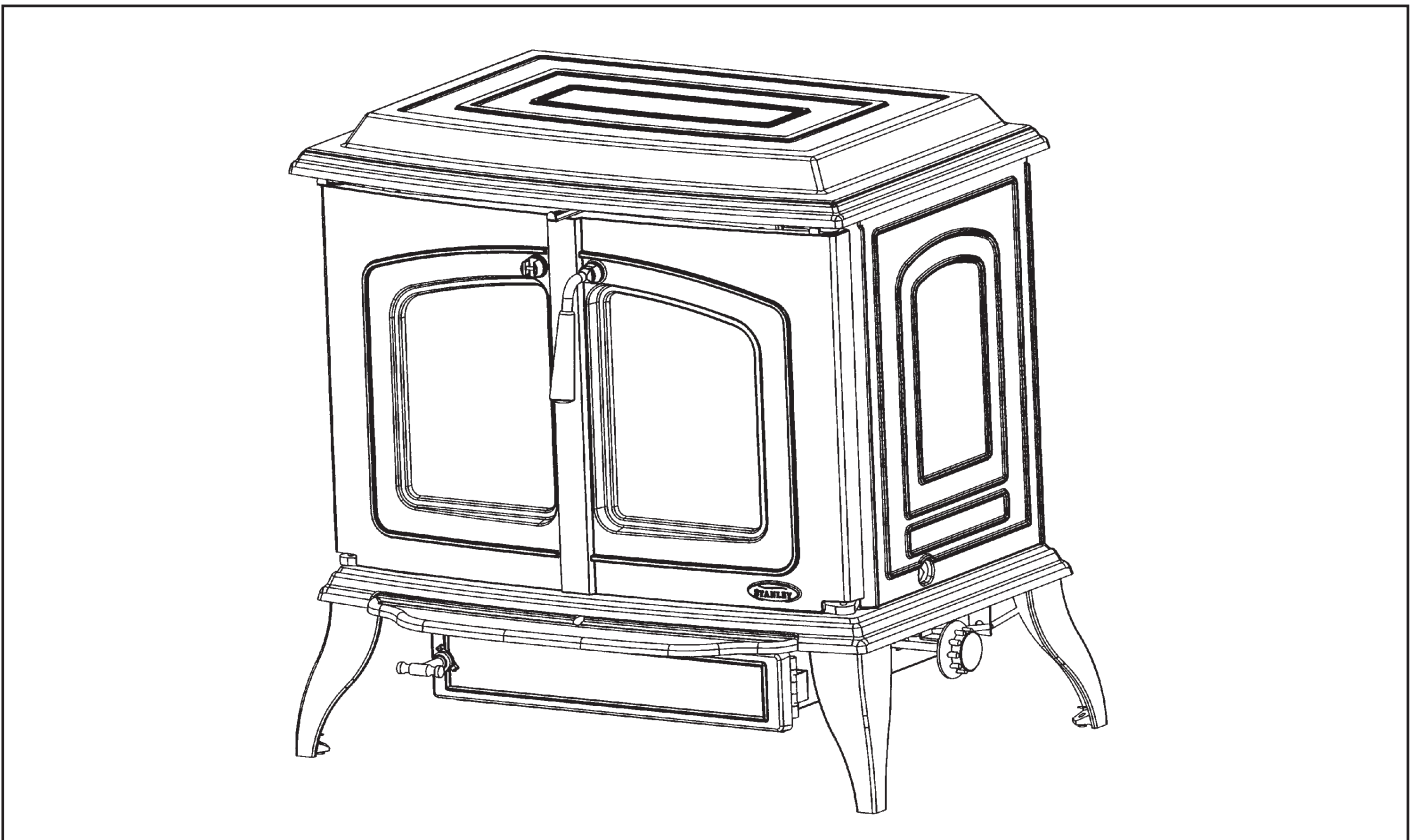

# GRAINNE

## Boiler & Non Boiler Solid Fuel Stove



### ***INSTALLATION AND OPERATING INSTRUCTIONS***

This appliance is hot while in operation and retains its heat for a long period of time after use. Children, aged or infirm persons should be supervised at all times and should not be allowed to touch the hot working surfaces while in use or until the appliance has thoroughly cooled.

**PLEASE READ THESE INSTRUCTIONS CAREFULLY BEFORE INSTALLATION.** These instructions cover the basic principles to ensure the satisfactory installation of the stove, although detail may need slight modification to suit particular local site conditions.

---

---

## TABLE OF CONTENTS

	PAGE NO.
1. General .....	3
2. Health & Safety Precautions .....	3
Handling .....	3
Fire Cement .....	3
Asbestos .....	3
Metal Parts .....	3
3. Pre Installation Assembly .....	3
4. Flues .....	3
5. Flue Pipes .....	4
6. Chimney .....	4
7. Down Draughts .....	4
8. Ventilation & Combustion Air Requirements .....	4
9. Permanent Air Vent .....	5
Extractor Fan .....	5
10. Commissioning & Handover .....	5
11. Flue Connection .....	5
12. Top Flue Exit .....	5
Boiler Model .....	5
Non-Boiler Model .....	5
13. Rear Flue Exit .....	6
Boiler Model .....	6
14. Location .....	6
15. Installation Clearances .....	6
16. Floor Protection .....	6
17. Technical Data .....	7
18. Specification .....	8
Non Boiler Model .....	8
Boiler Model .....	8
19. Plumbing (Boiler Model Only) .....	9
Regulations .....	9
Gravity Circuit .....	9
Injector Tee .....	9
Water Circuit Temperature .....	9
Pipe Thermostat .....	9
20. Operating Instructions .....	9
21. Low/Slumber Burn .....	10
22. Primary Air Control .....	10
23. Recommended Fuels .....	10
24. Opening Stove Door .....	11
25. Important Notes .....	12
26. Lighting .....	13

27.	De-Ashing .....	14
28.	Disposal of Ashes .....	14
29.	To Clean Chimney Outlet.....	14
	Boiler Model .....	14
	Non Boiler Model.....	14
30.	To Replace Damaged Grate or Grate Bar.....	14
	Boiler Model .....	14
	Non Boiler Model.....	14
31.	Periods of Prolonged Non-Use .....	15
32.	Fire Safety .....	15
33.	In Case of Fire .....	15
34.	Vitreous Enamel Cleaning .....	15
35.	Glass Cleaning.....	16
36.	Glass Replacement .....	16
37.	CO Alarm .....	16
38.	Exploded View - Boiler Model .....	17
39.	Exploded View - Non Boiler Model .....	18
40.	Installation Check List .....	19

## GRAINNE SOLID FUEL STOVE INSTALLATION & OPERATING INSTRUCTIONS

In all cases the installation must comply with current Building Regulations, Local Authority Bylaws and other specifications or regulations as they affect the installation of the stove.

**NOTE:** Please note that it is a legal requirement under England and Wales Building Regulations that the installation of the stove is either carried out under Local Authority Building Control approval or is installed by a Competent Person registered with a Government approved Competent Persons Scheme. HETAS Ltd operate such a Scheme and a listing of their Registered Competent Persons can be found on their website at [www.hetas.co.uk](http://www.hetas.co.uk).

### GENERAL

When installing, operating and maintaining your Grainne Stove respect basic standards of fire safety. Read these instructions carefully before commencing the installation. Failure to do so may result in damage to persons and property. Consult your local Municipal office and your insurance representative to determine what regulations are in force. Save these instructions for future reference.

### HEALTH AND SAFETY PRECAUTIONS

Special care must be taken when installing the stove such that the requirements of the Health and Safety at Work Act are met.

#### Handling

Adequate facilities must be available for loading, unloading and site handling.

#### Fire Cement

Some types of fire cement are caustic and should not be allowed to come into contact with the skin. In case of contact wash immediately with plenty of water.

#### Asbestos

This stove contains no asbestos. If there is a possibility of disturbing any asbestos in the course of installation then please seek specialist guidance and use appropriate protective equipment.

#### Metal Parts

When installing or servicing this stove care should be taken to avoid the possibility of personal injury.

### IMPORTANT WARNING

This stove must not be installed into a chimney that serves any other heating appliance. There must not be an extractor fan fitted in the same room as the stove as this can cause the stove to emit fumes into the room.

The installation must be completed in accordance with current National and European Standards and Local Codes. It should be noted that the requirements and these publications may be superseded during the life of this manual.

### PRE INSTALLATION ASSEMBLY

1. Remove the flue spigot (Non boiler only) and put in the orientation required. (See Flue Connections)
2. Remove the stove from the wooden pallet.

Fig.1

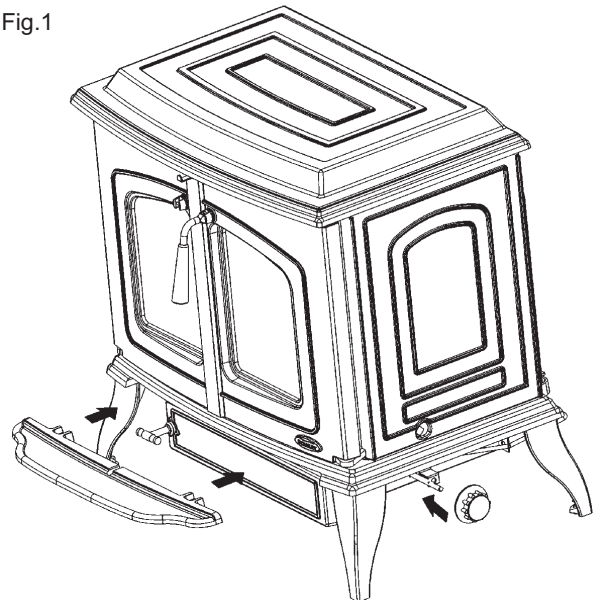

3. Unscrew the two  $\frac{1}{4}$ " x  $\frac{1}{2}$ " round head screws from the base and fit the front ash tray using the two screws.
4. Fit the primary air control knob to the flexible drive (see Fig.1).

### FLUES

Flues should be vertical wherever possible and where a bend is necessary, it should not make an angle of more than  $45^\circ$  with the vertical. Horizontal flue runs should be avoided except in the case of a back outlet from the appliance, when the length of the horizontal section should not exceed 150mm. In order to minimise flue resistance and to make sweeping easier it is recommended to use 2 x  $45^\circ$  bends rather than a  $90^\circ$  bend. The flue termination point must be located to minimise any wind effects. Wind effects of suction, pressure zones and turbulence can be created by the roof and adjacent

objects. Wind effects can also be created by natural land contours.

To minimise the wind effects, the flue termination point should be located a minimum of 1000mm from the roof measured vertically and 2300mm measured horizontally. Where this termination point does not suffice it may be necessary to extend the flue pipe so that the termination point is above the apex.

Fig.2

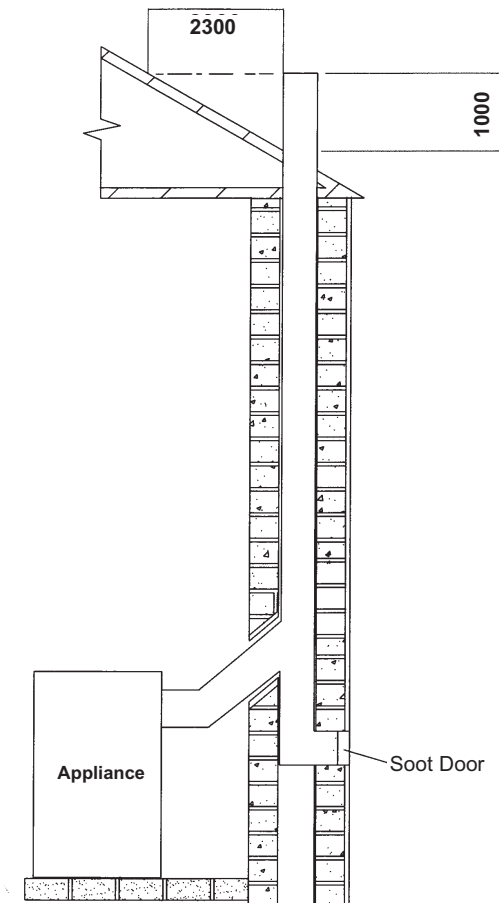

## FLUE PIPES

A flue pipe should only be used to connect an appliance to a chimney and should not pass through any roof space.

Flue pipes may be of any of the following materials:

- (a) Cast iron as described in BS 41: 1973 (1981), or
- (b) Mild steel with a wall thickness of at least 3mm, or
- (c) Stainless steel with a wall thickness of at least 1mm and as described in BS EN 10095: 1999 Specification for stainless and heat resisting steel plate, sheet and strip, for Grade 316 S11, 316 S13, 316 S16, 316 S31, 316 S33, or the equivalent Euronorm 88-71 designation, or
- (d) Vitreous enamelled steel complying with BS 6999: 1989.

Flue pipes with spigot and socket joints should be fitted with the socket uppermost.

## CHIMNEY

The stove is a radiant room heater and must be connected to a chimney of the proper size and type. The chimney must have a cross sectional area of at least 19350 square mm (30 square inches) or a diameter of 150mm (6"). The chimney should be checked for soundness and draught before installation. The stove must be connected to a chimney with a minimum continuous draught of 12pa. Poor draught will result in poor performance. Similarly an excessive draught will result in the appliance over firing or being difficult to control. An excessive draught may require a flue draught stabiliser to be fitted. Do not connect this appliance to a chimney serving another appliance. The minimum required chimney height is 4.5 metres from the floor on which the appliance is installed. An existing masonry chimney should be inspected and if necessary, repaired by a competent mason.

If the stove is fitted in place of an open fire then the chimney should be swept one month after installation to clear any soot falls which may have occurred due to the difference in combustion between the stove and the open fire.

## DOWN DRAUGHTS

However well designed constructed and positioned, the satisfactory performance of the flue can be adversely affected by down draught caused by nearby hills, adjacent tall buildings or trees. These can deflect wind to blow directly down the flue or create a zone of low pressure over the terminal. A suitable anti-down draught terminal or cowl will usually effectively combat direct down blow but no cowl is likely to prevent down draught due to a low pressure zone.

## VENTILATION & COMBUSTION AIR REQUIREMENTS

This appliance is rated at less than 9kW. It is imperative that there is sufficient air supply to the stove in order to support correct combustion. The air supply to this appliance must comply with B.S. 8303: Part 1 and current Building Regulations. The minimum effective air requirement for this appliance is 22cm<sup>2</sup>. If a draught stabiliser is used then this increases to 49cm<sup>2</sup>.

When calculating combustion air requirement for this appliance use the following equation: a total free area of at least 550mm<sup>2</sup> per kW of rated output above 5kW shall be provided. If there is another air using appliance fitted in the same or adjacent room, it will be necessary to calculate additional air supply. All materials used in the manufacture of air vents should be such that the vent is dimensionally stable and corrosion resistant.

---

The effective free area of any vent should be ascertained before installation. The effect of any screen should be allowed for when determining the effective free area of any vent.

Air vents direct to the outside of the building should be located so that any air current produced will not pass through normally occupied areas of the room. An air vent outside the building should not be located less than the dimensions specified within the Building Regulations from any part of any flue terminal. These air vents must also be fire proofed as per Building Regulations.

Air vents traversing cavity walls should include a continuous duct across the cavity. The duct should be installed in such a manner as not to impair the weather resistance of the cavity. Joints between air vents and outside walls should be sealed to prevent the ingress of moisture. Existing air vents should be of the correct size and unobstructed for the appliance in use. If there is an air extraction fan or other air using appliance fitted in the room or adjacent rooms where this appliance is fitted, additional air vents will be required to alleviate the possibility of spillage of products of combustion from the appliance/flue while the fan is in operation.

Where such an installation exists, a test for spillage should be made with the fan or fans and other appliances using air in operation at full rate, (i.e. extraction fans, tumble dryers) with all external doors and windows closed. If spillage occurs following the above operation, an additional air vent of sufficient size to prevent this occurrence should be installed.

## **PERMANENT AIR VENT**

The stove requires an adequate air supply in order for it to operate safely and efficiently. The installer may have fitted a permanent air supply vent into the room in which the stove is installed to provide combustion and/or ventilation air. This air vent should not under any circumstances be shut off or sealed.

### **Extractor Fan**

There must not be an extractor fan fitted in the same room as the stove as this can cause the stove to emit smoke and fumes into the room.

## **COMMISSIONING AND HANDOVER**

Ensure all parts are fitted in accordance with the instructions.

On completion of the installation allow a suitable period of time for any fire cement and mortar to dry

out, before lighting the stove. Once the stove is under fire check all seals for soundness and that the boiler and water system are operating correctly. Ensure that the flue is functioning correctly and that all products of combustion are vented safely to atmosphere via the chimney terminal.

On completion of the installation and commissioning ensure that the operating instructions for the stove are left with the customer. Ensure to advise the customer on the correct use of the appliance and warn them to use only the recommended fuels for the stove.

Advise the user what to do should smoke or fumes be emitted from the stove. The customer should be warned to use a fireguard to BS 6539 in the presence of children, aged and/or infirm persons.

## **FLUE CONNECTION**

Flue pipes with spigot and socket joints should be fitted with the socket upper most. Clearance to combustibles must be adhered to when fitting the flue pipe. The connecting flue pipe must not be less than the diameter of the stove outlet.

The flue gas mass flow non boiler model is 6.1g/s (mineral wood logs) and 7.9g/s (mineral fuel), with respective mean flue gas temperatures of 342°C and 294°C.

The flue gas mass flow boiler model is 6.1g/s (mineral wood logs) and 5.4g/s (mineral fuel), with respective mean flue gas temperatures of 220°C and 262°C.

## **TOP FLUE EXIT**

### **Boiler Model**

For the top outlet configuration, connect bend (not supplied) into flue outlet socket at the rear of the stove and cement into place using approved fire cement ensuring that no cement blocks the flue passageway. (See Fig. 3)

### **Non Boiler Model**

This stove can be connected to either a top flue exit (see Fig. 5 or a rear flue exit (see Fig.6) by simply reversing the orientation of the flue spigot on the flue spigot flange.



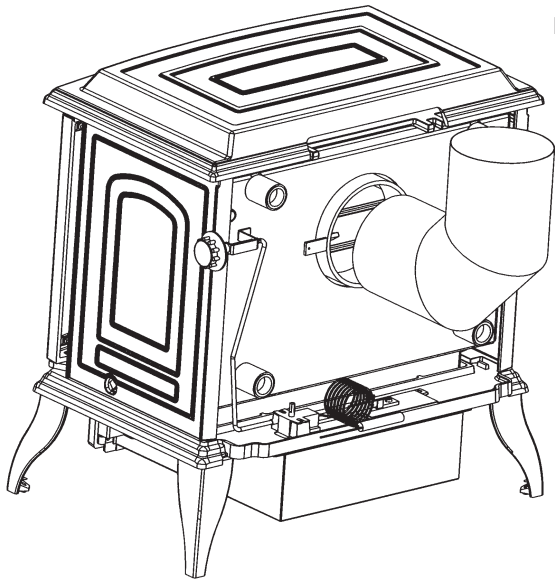

Fig 3

## REAR FLUE EXIT

### Boiler Model

For the rear flue outlet configuration, push in the flue connector pipe (not supplied) into the flue outlet socket at the rear of the stove and cement into place using approved fire cement ensuring that no cement blocks the flue passageway. (See Fig.4)

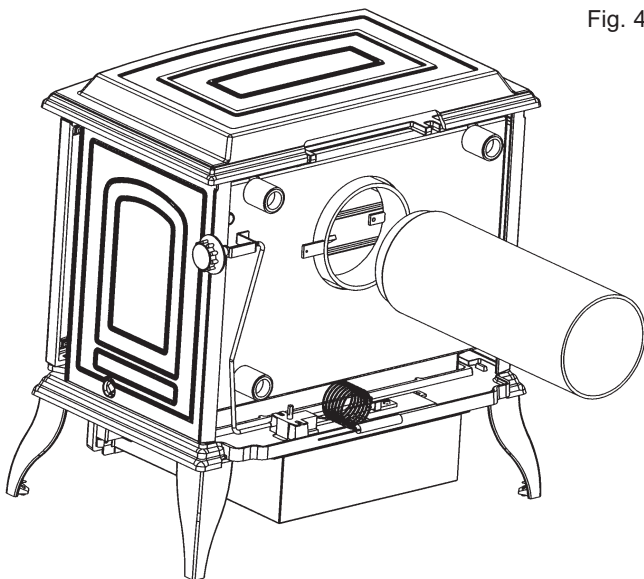

Fig. 4

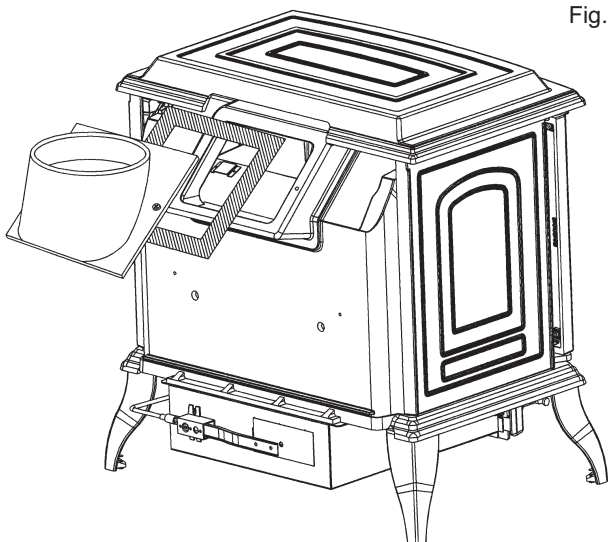
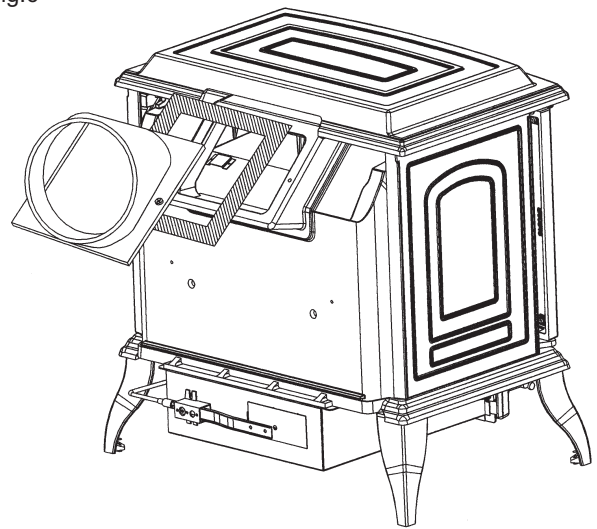

Fig. 5

Fig.6



## LOCATION

There are several conditions to be considered in selecting a location for your Grainne Stove.

- Position in the area to be heated- central locations are usually best.
- Allowances for proper clearances to combustibles.

**Note:** Sufficient space should be given around the back and sides of the stove to allow access to the air control damper.

## INSTALLATION CLEARANCES

Maintain at least the following clearances to all combustible material:

### Boiler Model

From the front	910 mm
From the back	150 mm
From the sides	150 mm
From the flue pipe	910 mm

### Non Boiler Model

From the front	910 mm
From the back	800 mm
From the sides	800 mm
From the flue pipe	910 mm

It is recommended that this appliance is sited next to and on a non-combustible surface. A minimum all round clearance of 100 mm will allow air circulation and not impede the performance of the stove.

## FLOOR PROTECTION

It is recommended that this appliance is installed on a solid, level, non combustible hearth conforming to current Building Regulations.

Fig.7

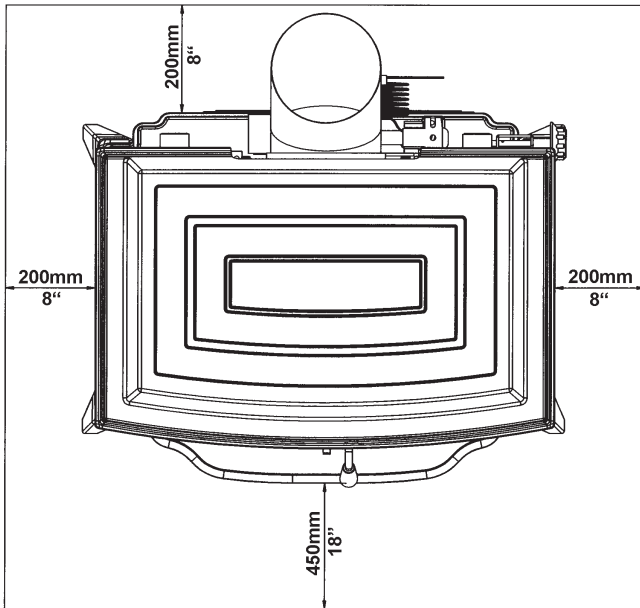

Mean Flue gas temperature directly downstream of the spigot at nominal output 317°C

The appliance is suitable for continuous operation on solid mineral fuel and intermittent operation on wood logs. This appliance has been tested using seasoned wood logs and manufactured briquettes smokeless fuel (Ancit) for closed appliances, sized between 20g and 140g. Other fuels are commercially available. Wood logs up to 400 mm long are suitable. All fuels should be stored under cover and kept as dry as possible prior to use.

**TECHNICAL DATA**

**BOILER MODEL**

	OUTPUT TO WATER		OUTPUT TO ROOM		TOTAL OUTPUT	
	NOMINAL	MAX.	NOMINAL	MAX.	NOMINAL	MAX.
<b>WOOD LOGS</b>	4.8		3.2		8	
<b>SOLID MINERAL FUEL</b>	4.5	9.67	3.4	6.1	7.9	15.8

**NON-BOILER MODEL**

	OUTPUT TO ROOM		TOTAL OUTPUT	
	NOMINAL	MAX.	NOMINAL	MAX.
<b>WOOD LOGS</b>	8.2		8.2	
<b>SOLID MINERAL FUEL</b>	8.5	12	8.5	12

**Flue Outlet Diameter:** 152mm

Typical refuelling intervals to obtain nominal outputs:

- 1.5 hours wood
- 4 hours solid mineral fuel

**Wood Log Size:** 400mm

**Gross Weight:** 167kgs



## SPECIFICATION - NON BOILER

Fig.8

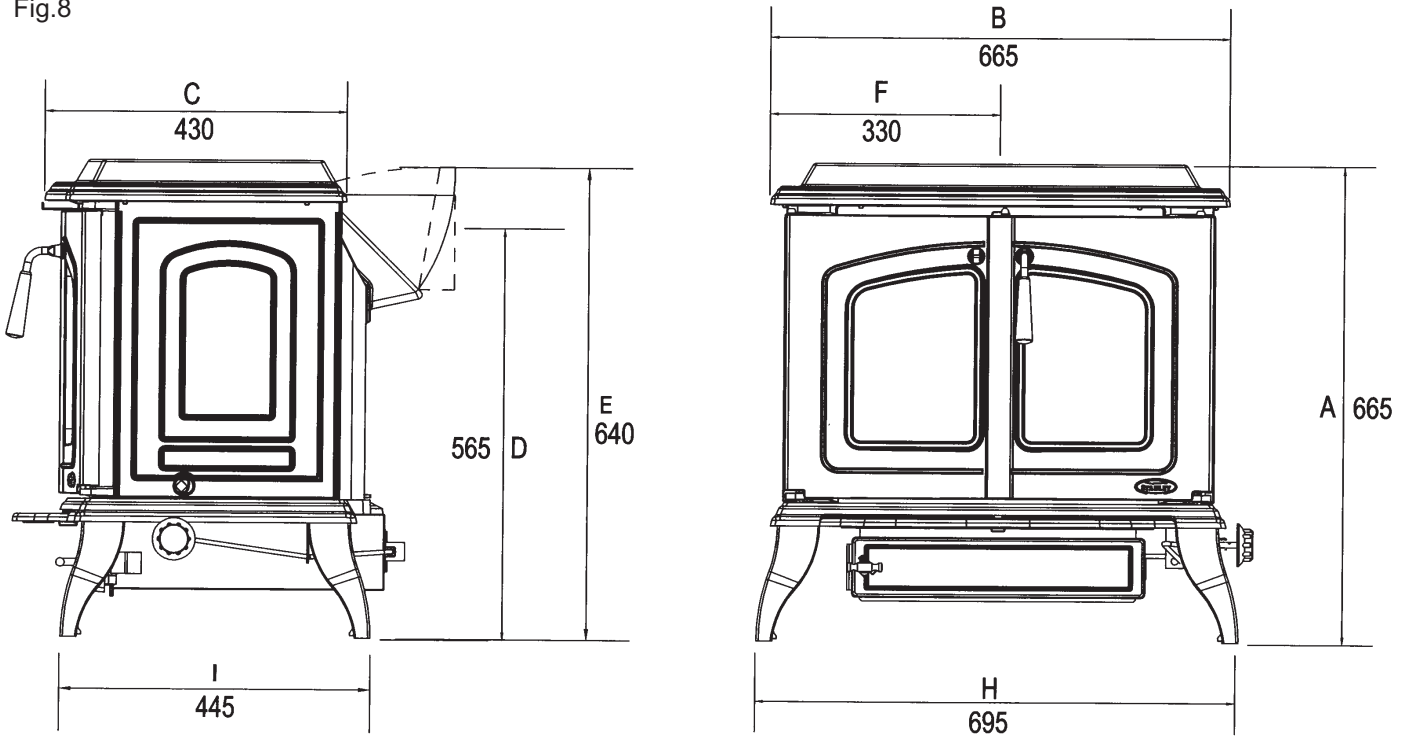

## SPECIFICATION - BOILER

Fig. 9

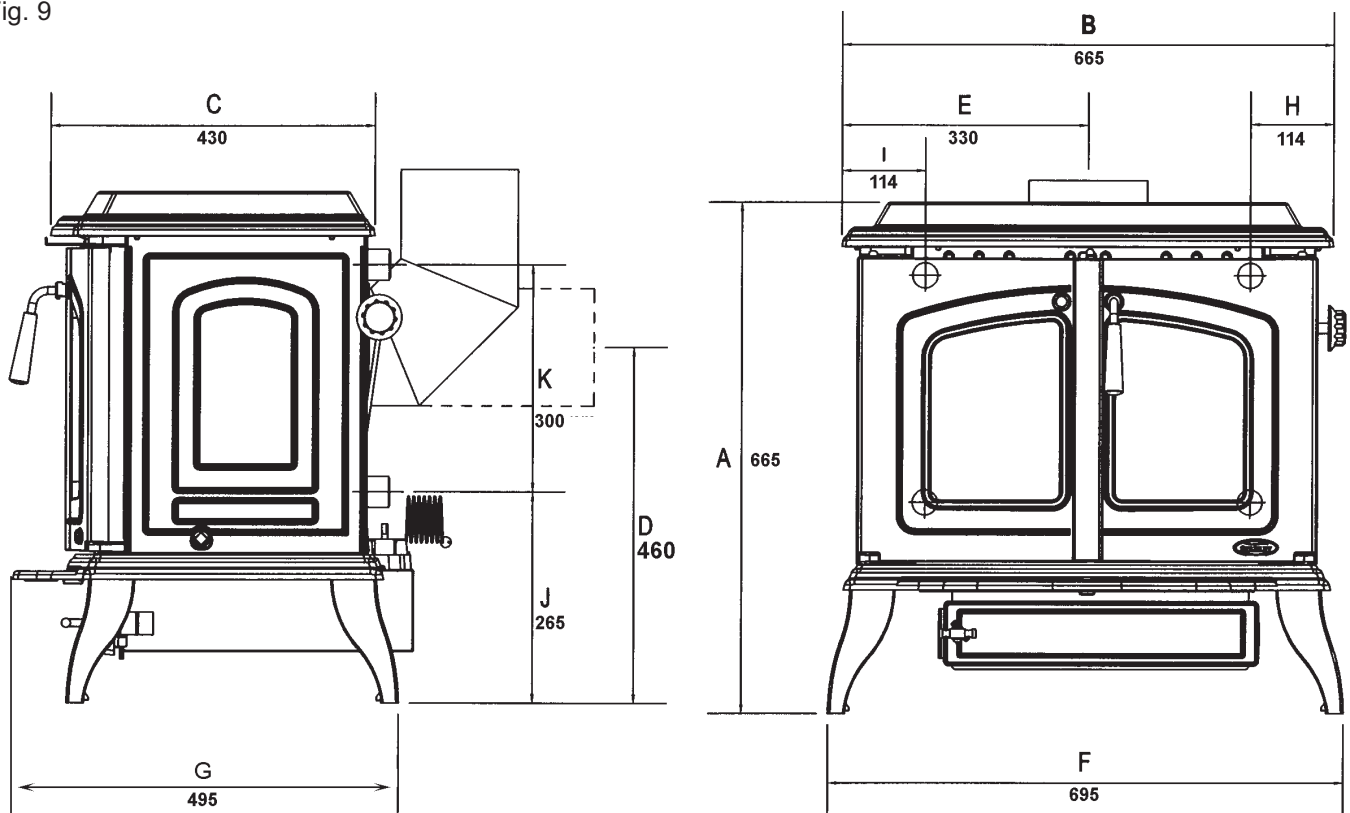

**Note:** Dimensions stated are in millimetres unless otherwise stated and may be subject to a slight +/- variation.

## PLUMBING (BOILER MODEL)

### REGULATIONS

The plumbing must be in accordance with all relevant regulations and practices. It must include a gravity circuit with expansion pipe, open to the atmosphere. The central heating will be pump-driven as with other types of boilers.

The installation of any electrical services during the installation of this boiler and the associated heating system must be carried out by a registered competent electrician and in accordance with the requirements of the latest issue of BS 7671.

The installation of the central heating system should be in accordance with BS 5449: code of practice for central heating systems for domestic premises.

### GRAVITY CIRCUIT

The gravity circuit consists of the domestic hot water tank of 135 litres indirect cylinder, fixed in an upright position, recommended for hot water storage and it should be connected to the boiler by 28mm diameter flow and return piping. The pipes should not exceed 7.8 meters (25ft) in length and cylinder and pipework should be fully lagged. The shorter the run of pipe work the more effective the water heating.

The domestic hot water cylinder should be to BS1566:Part1.

There must be no gate valves on this circuit and it must have an expansion pipe exhausting to atmosphere. Cylinder and pipe work should be lagged to minimise heat loss.

This diagram illustrates the basic principal of water heating systems and must not be regarded as a working drawing.

Fig.10

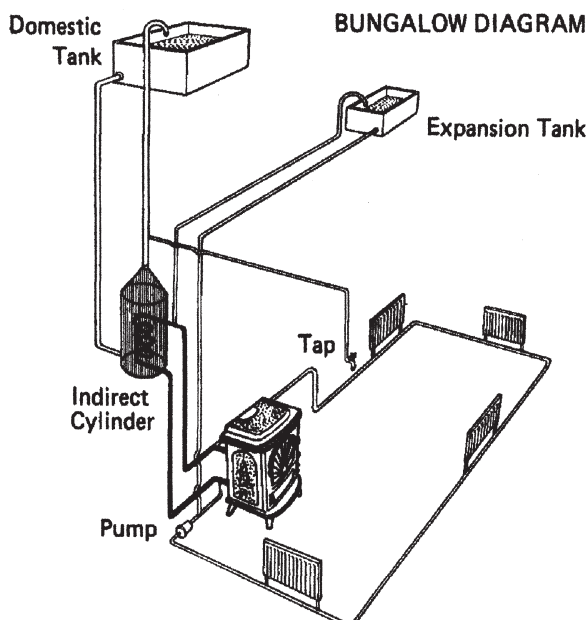

### INJECTOR TEE

Where the gravity and central heating circuits join together to return to the stove we recommend the use of an injector tee connection, situated as close to the unit as possible. This type of tee encourages a stable flow of water through both circuits and helps to prevent priority being given to the stronger flow, which is most commonly the pumped central heating circuit.

### WATER CIRCUIT TEMPERATURE

The return water temperature should be maintained at not less than 40°C so as to avoid condensation on the boiler and return piping. Fitting a pipe thermostat to the flow pipe of the gravity circuit and wiring it into the pump control will ensure rapid circulation of the hot water.

### PIPE THERMOSTAT

The fitting of a pipe thermostat to the flow pipe is essential in order to activate the water circulation pump when the water reaches the selected temperature.

When the water temperature falls below the selected temperature the pipe thermostat will cut off the water circulation pump in order to allow the boiler to recover.

Fig.11

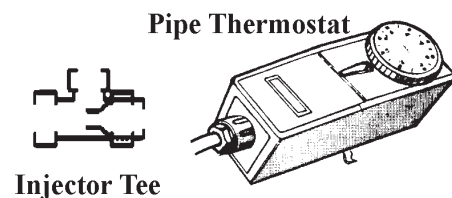

### OPERATING INSTRUCTIONS

COAL, ANTHRACITE, WOOD SYNTHETIC LOGS, OR OTHER FUELS. "Never use gasoline" gasoline type lantern fuel, kerosene, charcoal lighter fluid or similar liquids to start or 'freshen up' a fire in this heater. Keep all such liquid well away from the heater at all times. Operate stove only with fuelling door and ashpit doors closed. This heater is hot whilst in operation. Keep children, clothing and furniture a safe distance away.

## WARNING NOTE

Properly installed, operated and maintained this stove will not emit fumes into the dwelling. Occasional fumes from de ashing and re fuelling may occur. However, persistent fume emission is potentially dangerous and must not be tolerated. If fume emission does persist, then the following immediate action should be taken:

- (a) Open doors and windows to ventilate room
- (b) Let the fire out or eject and safely dispose of fuel from the appliance
- (c) Check for flue or chimney blockage and clean if required
- (d) Do not attempt to relight the fire until the cause of the fume emission has been identified and corrected. If necessary seek expert advice.

The most common cause of fume emission is flue-way or chimney blockage. For your own safety these must be kept clean at all times.

**WARNING** Do not attempt to light the stove if there is a possibility the heating system is frozen (boiler models only).

Never use an aerosol spray can near the stove when it is alight as there is a risk of an explosion or “flare up”.

## LOW / SLUMBER BURN

To achieve an overnight or a low burn rate, close the air wash slider fully by sliding the lever left using the ashpan tool and turn the primary air control knob to setting 0.

## PRIMARY AIR CONTROL

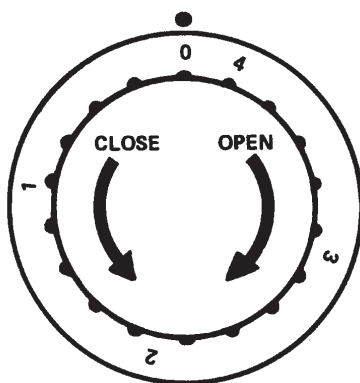

Fig.12

Setting 0:	Overnight Burning
Setting 1:	Closed
Setting 2:	Slow burning
Setting 3:	Medium burning
Setting 4:	Maximum Heat

Rotate the knob to the required setting. These are a guide only and experience will dictate the required setting for comfort.

## NOTE:-

A boiler model stove will provide heat into the boiler and also to the room in which it is situated. The heat to room is in a fixed relationship with the heat to the boiler.

The heat to the boiler is controlled by the air supply to the stove which is required to have a thermostatic damper for safety reasons. When the temperature of the water in the boiler exceeds 55 °C the thermostatic damper will begin to shut off the air supply, should the water temperature continue to rise the thermostatic damper will continue to close and if the water temperature reaches 85 °C the thermostatic damper closes the primary air supply fully.

In the event where a stove is fitted to a central heating system which is undersized in relation to the nominal heat output to boiler then the stove will operate satisfactorily but will be unable to achieve the nominal heat output to room as the thermostatic damper will shut off the air supply to prevent an overheat situation in the boiler.

**For example:-** Where a stove provides 2kW to the room and 8kW to the boiler and if the thermostatic damper shuts down the air supply to provide 4kW to the boiler, then the heat to room will decrease proportionally to 1kW.

## RECOMMENDED FUELS

This appliance has been tested using seasoned wood logs and manufactured briquetted smokeless fuel (Ancit) for closed appliances, sized between 20g and 140g. Other fuels are commercially available and may give similar results. Wood logs up to 400mm long are suitable. All fuels should be stored under cover and kept as dry as possible prior to use. Do not use fuels with a coke ingredient as this may cause the grate to overheat, causing damage. Reduced outputs will result when fuels of lower calorific values are used. Never use gasoline or gasoline type lantern fuel, kerosene, charcoal lighter fluid or similar liquids to start or freshen up a fire in this heater. Keep all such liquid well away from the heater at all times. Operate the stove only with the fuelling door closed except for re-fuelling.

Fig.13

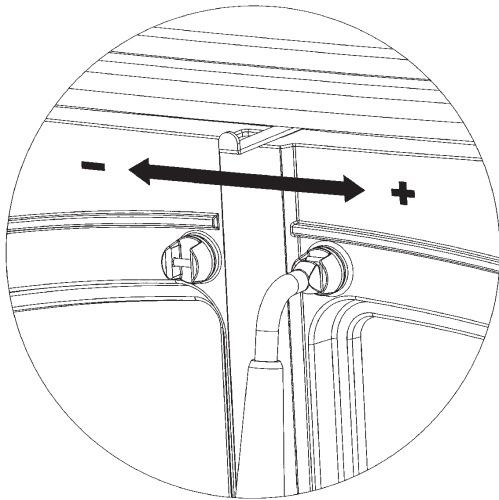

**OPEN**  
**CLOSE**

When burning coal, timber or peat.  
When burning anthracite and smokeless fuels. See Fig.13

**WARNING: THE AIR SLIDER IS HOT WHILE STOVE IS IN USE - USE TOOL TO OPERATE.**

**WARNING: DO NOT OBSTRUCT PRIMARY AIR SUPPLY TO THE AIR DUCT AT THE BACK OF THE STOVE.**

**OPENING STOVE DOOR**

The stove is provided with a removable handle. The door opening mechanism is operated by sliding the handle onto the door latch shaft located on the right hand door. Slide the handle up from underneath into the door latch as shown in Fig.14.

When the handle is fully engaged, rotate the handle in an anticlockwise direction to open the door see Figs 15 & 15a.

Reverse the above procedure to lock the door. The door latch shaft on the left hand door is fixed and cannot be rotated. If you require to open this door whilst hot, slide the handle on from top down to the bottom in a vertical direction and then use the handle to pull the door open. The right hand door must be open to allow the left hand door to open.

Fig.14

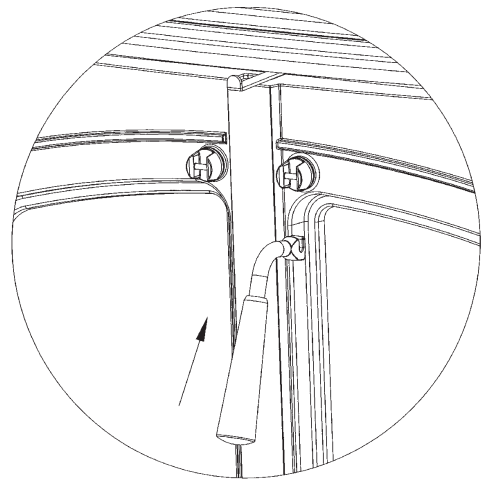

Fig.15

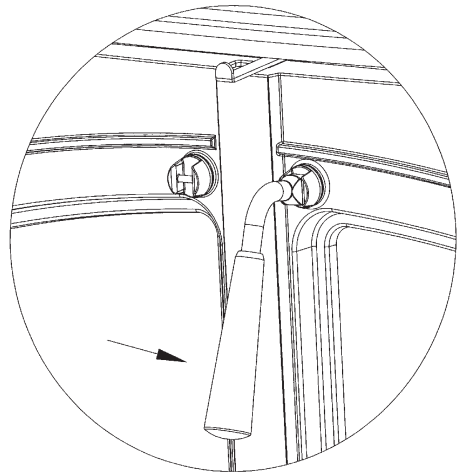
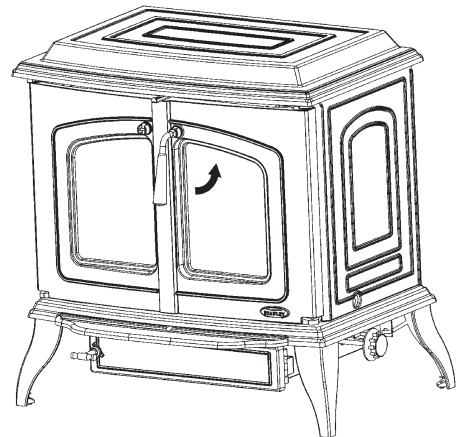

Fig.15a



---

## IMPORTANT NOTES

Now that your Solid Fuel Stove is installed and no doubt you are looking forward to many comforts it will provide, we would like to give you some tips on how to get the best results from your stove.

1. We would like if you could take some time to read the operating instructions/hints, which we are confident, will be of great benefit to you.
2. Do not burn fuel with a high moisture content, such as a damp or unseasoned timber. This will only result in a build up of tar in the stove and in the chimney.

<b>FUEL CALORIFIC VALUES - SOLID FUELS</b>		
Anthracite 25-50mm	C.V.: 8.2kW/Kg	14,000 BTUs/lb
House Coal 25-75mm	C.V.: 7.2kW/Kg	12,000 BTUs/lb
Timber - Firebox size	C.V.: 5.0kW/Kg	8,600 BTUs/lb
Peat Briquettes	C.V.: 4.8kW/Kg	8,300 BTUs/lb

3. Clean the flue-ways of the stove weekly and ensure that there are no blockages. Check flueways before lighting especially after a shut down period. Please refer to manual for instructions.
4. Before loading fresh fuel into the firebox, riddle fully to remove all ashes, this will allow better and cleaner burning. See Re-Fuelling Section.
5. Never allow a build up of ashes in the ash pan, as this will cause the grate to burn out prematurely. Empty the ashpan when re-fuelling.
6. Allow adequate air ventilation to ensure plenty of air for combustion.
7. Do not use as an incinerator burning rubbish/household waste.
8. Do not leave ash door open for long periods as this will over heat the unit causing unnecessary damage. Close the ash door between removing and replacing the ashpan.
9. Clean the chimney at least twice a year.
10. Burning soft fuels such as timber or peat will stain the glass. Regular cleaning will prevent permanent staining. Clean with soapy water when cool.
11. Keep all combustible materials a safe distance away from unit, please consult manual for clearance to combustibles table.
12. For safety reasons never leave children or the elderly unaccompanied while stove is in use. Use a fire guard.
13. Avoid contact with the appliance when in use as stove reaches very high operating temperatures.
14. This appliance should be regularly maintained by a competent service engineer.
15. Store the operating tool / door handle on the ash door on the bottom of the stove. **DO NOT STORE THIS HANDLE ON EITHER OF THE FIREBOX DOORS AS THE HANDLE WILL GET EXCESSIVELY HOT WHILE THE STOVE IS IN OPERATION.**

Use only replacement parts recommended by Waterford Stanley. Making unauthorised modifications, or using unauthorised parts will invalidate your guarantee and may cause damage or injury.

---

## **LIGHTING**

- 1. Before lighting the stove, ensure that any build up of ashes in the fire box has been removed and that the ashpan has been emptied.**
- 2. Open the firebox and cover the grate with crumpled pieces of paper.**
- 3. Lay pieces of kindling on top of the paper towards the back of the fire box.**
- 4. Open the primary air inlet by turning the control knob to setting 4.**
- 5. Open the secondary air control by sliding the control lever located over the top of the fire door to the right. (See Fig.13).**
- 6. Ignite the paper and close the fire door.**
- 7. When the kindling is well alight, open the fire door and add more kindling of a larger size to sustain the fire. Close the fire door. Do not operate this appliance with the fire door open.**
- 8. Never use inflammable liquid i.e. gasoline, petrol paraffin etc. to start or freshen up a fire in this heater.**
- 9. When a hot bed of fuel is established, add the normal fuel load and adjust the air controls to the required setting.**
- 10. When re-fuelling open the fire door and reload, close the fire door.**
- 11. To shut the fire down, do not add fuel, make sure that the fire door is properly closed and that the primary and secondary air controls are all in the closed position. Cutting off the air supply will reduce the heat output.**

**This appliance is hot whilst in operation.**

**Keep children, clothing and furniture a safe distance away.**



## DE-ASHING

When ash build-up becomes excessive in the fire chamber shake the firebars by inserting the operating tool/door handle into the round slot on the right side of the stove, twisting clockwise and anti-clockwise. A poker is also provided for de-ashing.

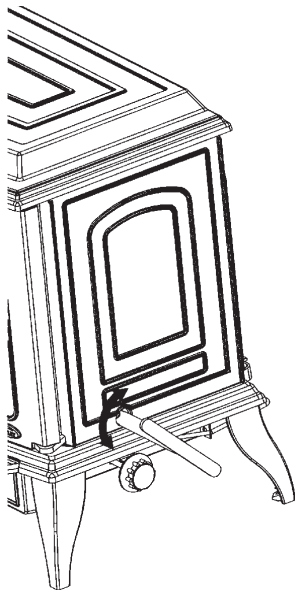

Fig.16

## DISPOSAL OF ASHES

The stove is provided with a steel ashpan. This ashpan must be emptied every day. If ashes are allowed to build up to grate level the firebars could be damaged by overheating. We recommend that you remove ashes after you have riddled the fire following an overnight burn.

**Note:** The stove should never be operated with the ashpit door open.

Ashes should be placed in a metal or other non-combustible container with a tight fitting lid. The closed container of ashes should be placed on a non-combustible material, pending final disposal. If ashes are buried in soil, or otherwise dumped they should be retained in the closed container until they are thoroughly cooled.

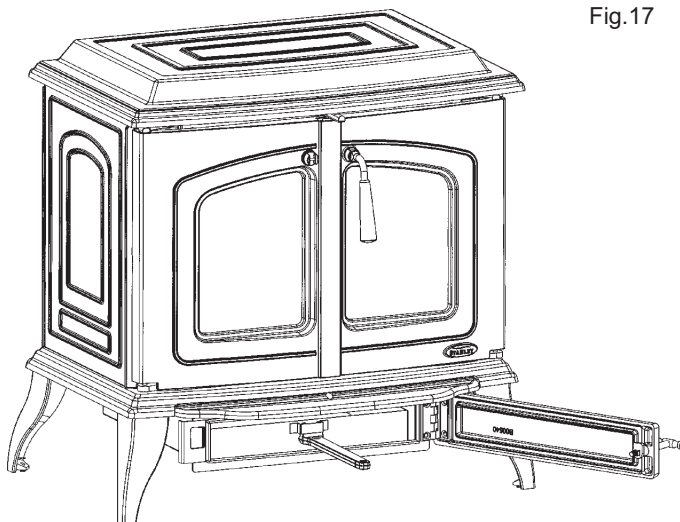

Fig.17

## TO CLEAN CHIMNEY OUTLET

### Boiler Model

Remove baffle underneath the boiler cross flow chamber by lifting it upwards and pulling it outwards and insert cleaning brush. Replace baffle before lighting fire.

Fig.18

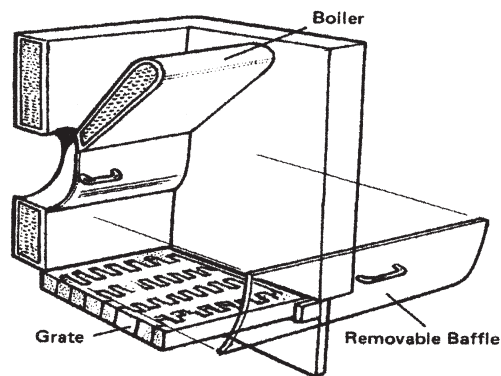

### NON BOILER MODEL

Remove hob and place to one side, taking care not to damage the enamel finish. Remove the hotplate and inner top by unscrewing the four 1/4" hex head bolts and insert the cleaning brush. Replace the hotplate and inner-top, ensuring that the rope on the bottom of the inner-top has not moved out of position or been damaged. Replace the hob before relighting the fire.

## TO REPLACE DAMAGED GRATE OR GRATE BAR

### BOILER MODEL

Remove the two sets of side firebricks and the front firebrick from the stove, taking care not to damage or break the bricks in the process. Tilt the grate assembly up on the left hand side, and pull towards the left hand side of the stove, until the front bar is clear of the right hand side of the stove (See Fig. 19). Remove the grate bars from the firebox and then remove the grate frame, replace the damaged part and reassemble the grate system by firstly replacing the grate frame, and the grate bars, and replacing finally the firebricks.

### NON - BOILER MODEL

Remove the front brick, the back brick, all the left hand side bricks and both small right side bricks from the stove, taking care not to damage or break any of the bricks in the process. Tilt the grate assembly up on the left hand side of the stove and pull towards the left side of the stove until the driven

rocker bar is clear of the right hand firebricks. Remove the grate assembly from the firebox, replace the damaged part and reassemble the firebox by re-positioning the grate assembly and then reposition all the firebricks.

Ensure the riddling mechanism works properly from outside the stove before replacing the firebricks.

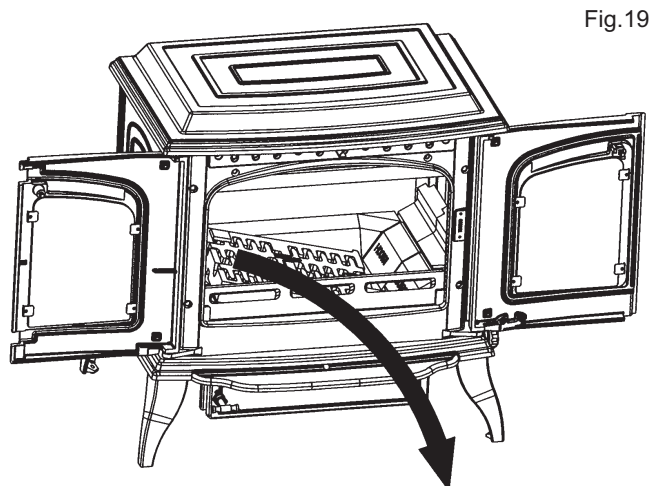

Fig.19

### PERIODS OF PROLONGED NON-USE

If the stove is to be left unused for a prolonged period of time then it should be given a thorough clean to remove ash and unburned fuel residues. To enable a good flow of air through the appliance to reduce condensation and subsequent corrosion damage, leave the air controls in the fully open position.

### FIRE SAFETY

To provide reasonable fire safety, the following should be given serious consideration.

1. **DO NOT OVER FIRE THE STOVE.**
2. **OVER-FIRING WILL ALSO DAMAGE PAINTED OR ENAMEL FINISH.**
3. Install a smoke detector in the room.
4. A conveniently located class A fire extinguisher to contend with small fires resulting from burning embers.
5. A practical evacuation plan.
6. A plan to deal with a chimney fire as follows:-
  - (a) Notify the fire department.
  - (b) Prepare occupants for immediate evacuation.

- (c) Close all openings into the stove.
- (d) While awaiting the fire department watch for ignition to adjacent combustibles from over heated flue pipe or from embers or sparks from the chimney.

Fig.20

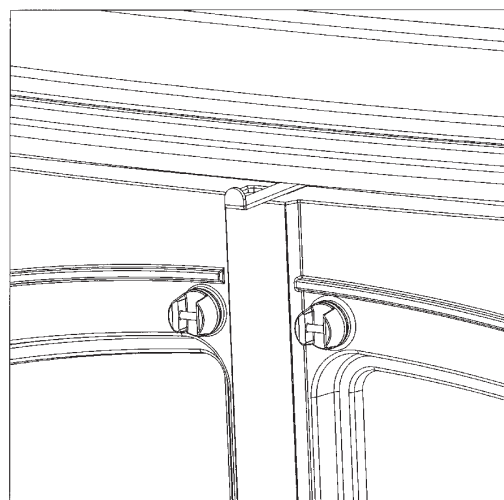

**STAINLESS STEEL DOOR AXLES MAY TARNISH PARTICULARLY IF STOVE IS OVERFIRED**

### IN CASE OF FIRE

Close all openings into the stove and watch for ignition of adjacent combustibles from over heated stove, or hot embers or sparks from chimney.

### VITREOUS ENAMEL CLEANING

General cleaning must be carried out when the stove is thoroughly cool.

If this stove is finished in a high gloss vitreous enamel, to keep the enamel in the best condition observe the following tips:

1. Wipe over daily with a soapy damp cloth, followed by a polish with a clean dry duster.
2. For stubborn deposits a soap impregnated pad can be carefully used on the vitreous enamel.
3. Use only products recommended by the Vitreous Enamel Association, these products carry the Vitramel label.

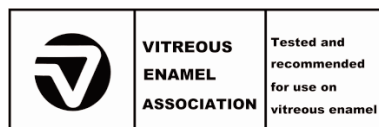

4. **DO NOT USE ABRASIVE PADS OR OVEN CLEANSERS CONTAINING CITRIC ACID ON ENAMELLED SURFACES. ENSURE THAT THE CLEANSER MANUFACTURERS INSTRUCTIONS ARE ADHERED TO.**

## GLASS CLEANING

The glass will self clean when there is sufficient heat generated by the burning fuel. If a build-up of creosote occurs on the glass it may be due to draft conditions, poor quality fuel or very low burning for a long time. It is best to clean the glass when it is thoroughly cooled.

## GLASS REPLACEMENT

- (a) Open the fire door fully.
- (b) Remove the screws and the four segments of the window frame and carefully remove the broken glass.
- (c) Clean the glass recess in the door.
- (d) Attach adhesive thermal tape to the perimeter of the replacement glass.
- (e) Place the thermal tape side of the glass into the door recess and replace the four segments of the window frame.
- (f) Tighten screws.
- (g) Replace glass only with ceramic glass 5mm thick. (See Fig.21)

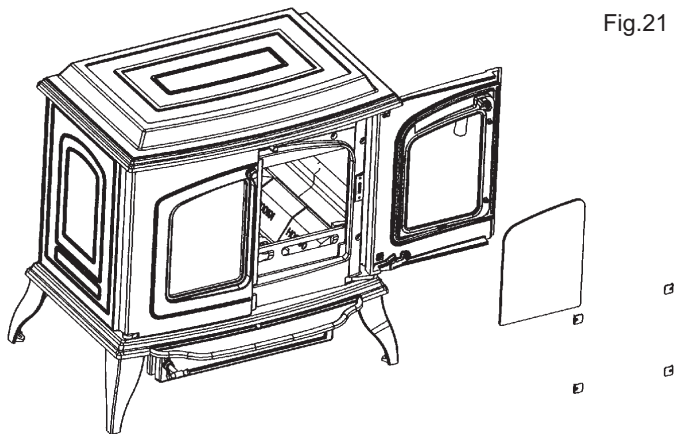

## CO ALARM

Waterford Stanley recommend the fitting of a CO Alarm in the same room as the appliance, this is a requirement under UK Building Regulations. Further guidance on the installation of a carbon monoxide alarm is available in BS EN 50292:2002 and from the alarm manufacturers instructions.

**Provision of an alarm must not be considered a substitute for either installing the appliance correctly or ensuring regular servicing and maintenance of the appliance and chimney system.**

### **WARNING:-**

**If the CO Alarm sounds unexpectedly:-**

- 1. Open Doors and windows to ventilate the room and then leave the premises.**
- 2. Let the fire go out.**

## GRAINNE SOLID FUEL- HPB MODEL EXPLODED VIEW

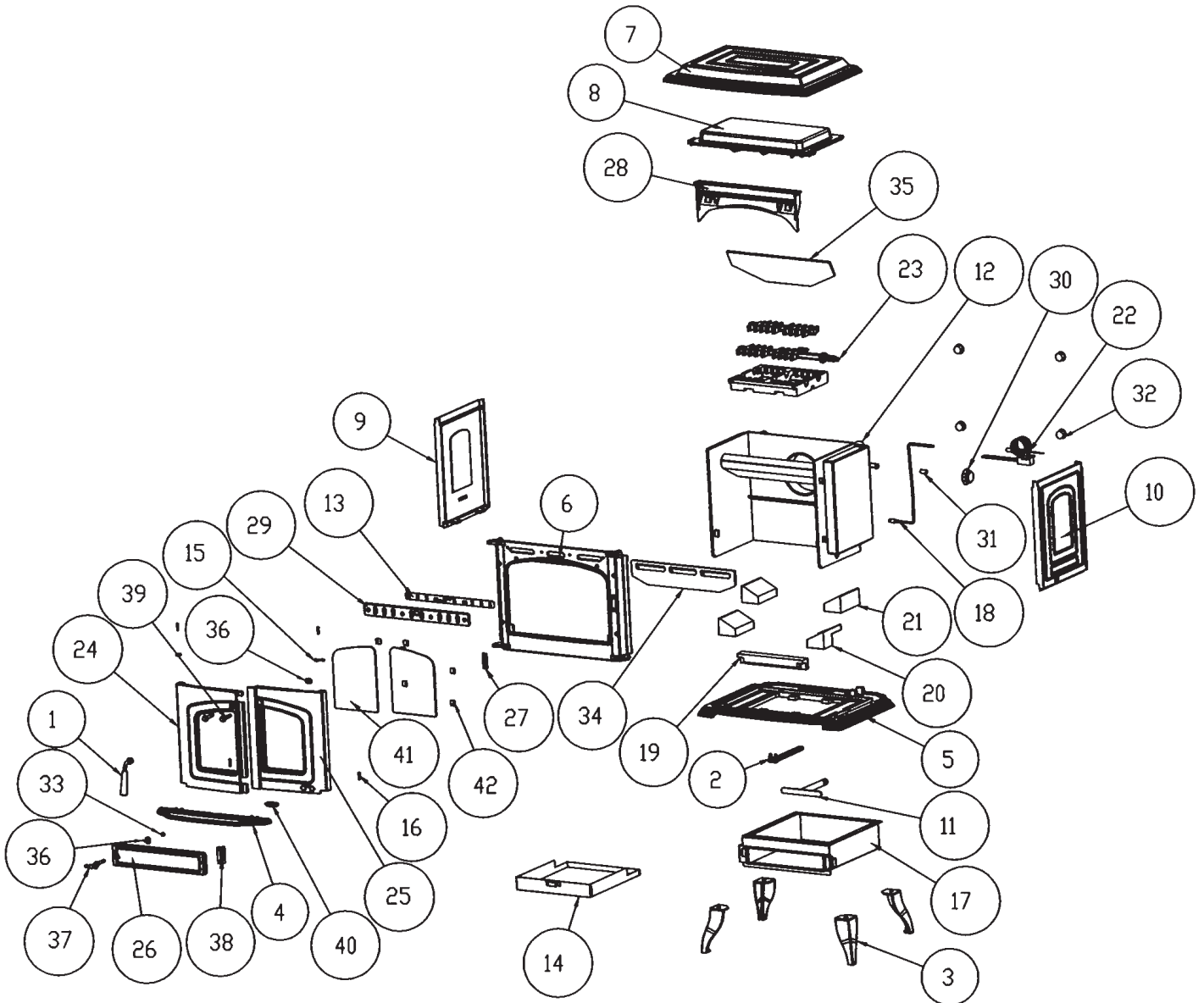

1. HANDLE	16. HINGE PIN	31. 25MM SPACER
2. OPERATING TOOL	17. ASH COMPARTMENT	32. BOILER PLUG
3. LEG	18. FLEXIBLE DRIVE	33. DOOR HANDLE SPACER
4. ASHTRAY FRONT	19. FRONT BRICK	34. FIRE FENCE
5. BASE PANEL	20. SIDE BRICK NO.1	35. BOILER CLEANING DOOR
6. FRONT	21. SIDE BRICK NO.2	36. DOOR LATCH
7. HOB	22. THERMOSTAT ASSEMBLY	37. ASHPIT DOOR HANDLE
8. INNER TOP	23. GRATE ASSEMBLY	38. HINGE
9. LH SIDE	24. LH FIRE DOOR	39. DOOR AXLE
10. RH SIDE	25. RH FIRE DOOR	40. BADGE
11. RIDDLING HANDLE	26. ASH DOOR	41. GLASS
12. BOILER	27. SERIAL NUMBER PLATE	42. WINDOW CLIP
13. AIR SLIDE SUB ASSEMBLY	28. BOX AIR WASH	
14. ASHPAN	29. AIR WASH CASTING	
15. DOOR STOP	30. AIR CONTROL KNOB	

## GRAINNE SOLID FUEL- NON BOILER MODEL EXPLODED VIEW

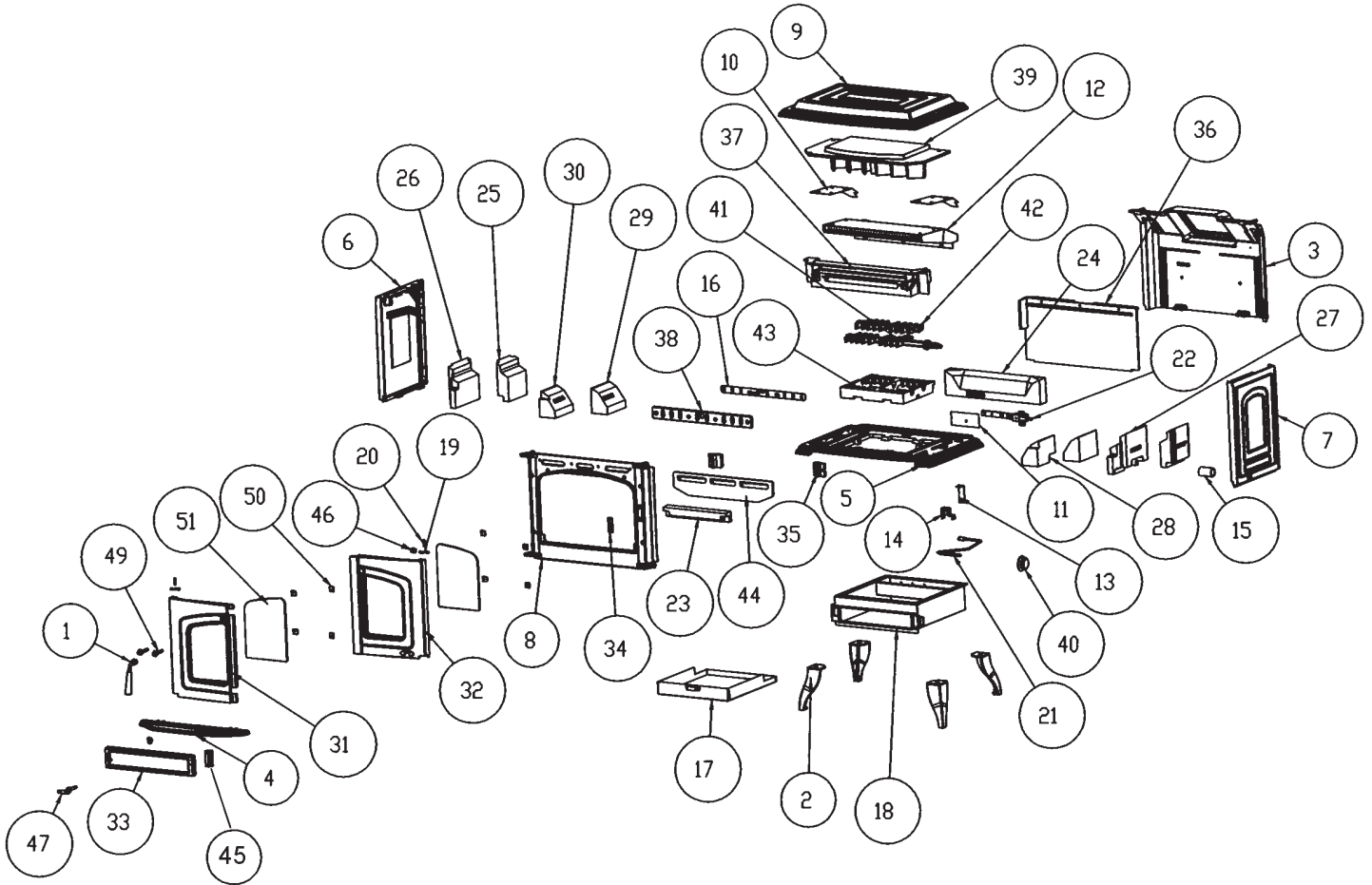

1. HANDLE	18. ASH COMPARTMENT ASSEMBLY	35. FIRE FENCE SUPPORT
2. LEG	19. DOOR STOP	36. BACK PANEL
3. OUTER BACK	20. HINGE PIN	37. EXTERNAL AIR WASH CASTING
4. ASHTRAY FRONT	21. FLEXIBLE DRIVE	38. AIR WASH CASTING
5. BASE PANEL	22. QWX THERMOSTAT	39. INNER TOP
6. LH SIDE	23. FRONT BRICK	40. AIR CONTROL KNOB
7. RH SIDE	24. BACK BRICK	41. ROCKER BAR (DRIVEN)
8. FRONT	25. SIDE BACK BRICK	42. ROCKER BAR (IDLE)
9. HOB	26. LEFT FRONT BRICK	43. GRATE
10. TOP AIR DUCT WINGS	27. RIGHT FRONT BRICK	44. FIRE FENCE
11. AIR CONTROL STAT PLATE	28. SIDE BRICK NO.1	45. HINGE
12. TOP AIR DUCT ASSEMBLY	29. SIDE BRICK NO.2	46. DOOR LATCH
13. FLEXIBLE DRIVE REST. BRACKET	30. LH FRONT BRICK NO.2	47. ASH DOOR HANDLE
14. FLEXIBLE DRIVE BRACKET	31. LH FIRE DOOR	48. BADGE
15. SHAKER BAR SLEEVE	32. RH FIRE DOOR	49. DOOR AXLE
16. AIR SLIDE SUB ASSEMBLY	33. ASH DOOR	50. WINDOW CLIP
17. ASHPAN	34. SERIAL NUMBER PLATE	51. GLASS

## INSTALLATION CHECK LIST

### Flue System

Tick

1. Minimum Flue Height of 4.6 metres (15 feet).
2. Appliance should be connected to a minimum of 1.8 metres (6 feet) of 150mm (6") flue pipe with a horizontal run not exceeding 150mm (6").
3. Appliance should be connected to a chimney of less than 200mm (8") in diameter (otherwise the chimney must be lined with a 6" flue liner).
4. The chimney venting position must be above the main ridge of the roof or adjacent outside obstructions.
5. The chimney serving this appliance should not serve any other appliance.
6. Access should be provided to the chimney serving the appliance to allow for cleaning.

### Location

7. Clearance to combustible materials must be adhered to as described in the Clearance to Combustible section.
8. The stove must be installed on a floor protector that covers the area under the stove and extends 18" to the front & 8" to the sides and back.

### Plumbing (Boiler Model Only)

9. Appliance must be connected to a gravity circuit using 1" ID flow & return piping.
10. The length of pipes from the cylinder to the cooker should not exceed 7.8 metres (25<sup>1</sup>/<sub>2</sub> feet).
11. A circulation pump should be fitted to the return pipe of the radiator circuit and controlled by a pipe stat fitted to the flow pipe of the gravity circuit to the cylinder.

### Ventilation & Combustion Air Requirements

12. The room in which the appliance is located should have an air vent of adequate size to support correct combustion (see Ventilation & Combustion Air Requirement Section for specific details).

**Manufactured by**  
**Waterford Stanley Ltd.,**  
Unit 401-403, IDA Industrial Estate, Cork Road,  
Waterford, Ireland.  
Tel: (051) 302300 Fax (051) 302315  
Website: [www.waterfordstanley.com](http://www.waterfordstanley.com)

