



BRANDON DRY & DHW OIL MODELS



TO BE INSTALLED BY A TRAINED COMPETENT PERSON

Installation and Commissioning Instructions

THIS MANUAL IS TO BE LEFT WITH END USER

TABLE OF CONTENTS

	PAGE NO.
1. Introduction	2
2. Specification	3
3. Technical Data	4
4. Schematic	5
5. Location	6
6. Hearth Construction	6
7. Electrical Supply	6
8. Cooker Clearances	6
9. Reduced Clearances	7
10. Pre-Installation Check	8
11. Flues	8
12. Chimney's	8
13. Sealing	9
14. Flue Height	9
15. Connections	9
16. Suitable Materials	10
17. Flue Cleaning	10
18. Use of Existing Chimneys and Flues	10
19. Draught Requirements	10
20. Flue Liners	10
21. Factory Made Insulated chimneys	10
22. Ventilation and Combustion Air Requirements	11
23. Outside Air Connection	11
24. Down Draughts	12
25. Wiring Diagram - Mechanical Timer	13
26. Wiring Diagram - Digital Timer	14
26. Domestic Hot Water System (DHW Model Only)	15
27. System	15
28. Safety Valve	15
29. Pipe Fittings	15
30. Direct Domestic Cylinder	15
31. Indirect Domestic Cylinder	15
32. Pipe Thermostat	16
33. Fuel Installation	16
34. Oil Storage Tanks	16
35. Fuels	16
36. Fuel Supply Line	16
37. Single Pipe Supply System	17
38. Two Pipe Supply System	17
39. Single Pipe System	17
40. Commissioning Checks	18
41. Function	19
42. General Maintenance	19
43. Servicing	19
44. Installation Check List	20
45. Door Handle Replacement Instructions	21

Introduction

Congratulations on purchasing this fine Irish made Oil-fired Cooker. It is built to exacting standards and it will give you every satisfaction in use. We invite you to read carefully the operating and installation instructions provided. This will enable you to familiarise yourself with this appliance.

This appliance is hot while in operation and retains its heat for a long period of time after use. Children, aged or infirm persons should be supervised at all times and should not be allowed to touch the hot working surfaces while in use or until the appliance has thoroughly cooled.

To ensure safety, satisfaction and reliable operation, this quality cooker should be installed by a trained and competent person.

Please note for DHW Models the domestic hot water facility involved must fully conform to good plumbing practices, established standards, Regulations and OFTEC Recommendations.

The complete installation must be done in accordance with current Standards and Local Codes. It should be noted that the requirements and these publications may be superseded during the life of this manual.

As manufacturers and suppliers of cooking and heating appliances, we take every possible care to ensure, as reasonably practicable, that these appliances are so designed and constructed as to meet the general safety requirements when properly used and installed.

* Section 10 of the Consumer Protection Act 1987.

* Safety, Health and Welfare at Work Act.

IMPORTANT NOTICE: Any alteration to this appliance that is not approved in writing by Waterford Stanley will render the guarantee void.

IMPORTANT — Control of Substances Harmful to Health:

It is the Users/Installers responsibility to ensure that the necessary personal protective clothing is worn when handling materials that could be interpreted as being injurious to health and safety.

When handling Firebricks, Fire Cement or Fuels, use disposable gloves.

Exercise caution and use disposable masks and gloves when handling glues and sealants.

When working with fibre glass, mineral wool, insulation materials, ceramic blanket/board or kerosene fuel oil, avoid inhalation as it may be harmful. Avoid contact with skin, eyes, nose and throat. Use disposable protection. Installation should be carried out in a well ventilated area.

This installation must comply with the following:

The Building Regulations: Part J England & Wales, Part F Section 4 Scotland, Part L Northern Ireland and Part J Ireland.

B.S. 7671: Requirements for Electrical Regulations.

Safety Document 635: The Electricity at Work Regulations.

B.S. 5410: Oil Installations Part 1 under 45 kW.

The Control of Pollution (Oil) Regulations Health & Safety at Work Act.

FOR DHW MODELS ADDITIONALLY THE INSTALLATION MUST COMPLY WITH THE FOLLOWING:

B.S. 7593: Treatment of Water in Domestic Hot Water Systems.

B.S. 7074: Parts 1 & 2: Hot Water Supply.

The manufacturers reserve the right to make alterations to design, materials or construction for manufacturing or other reasons subsequent to publication.

Specification

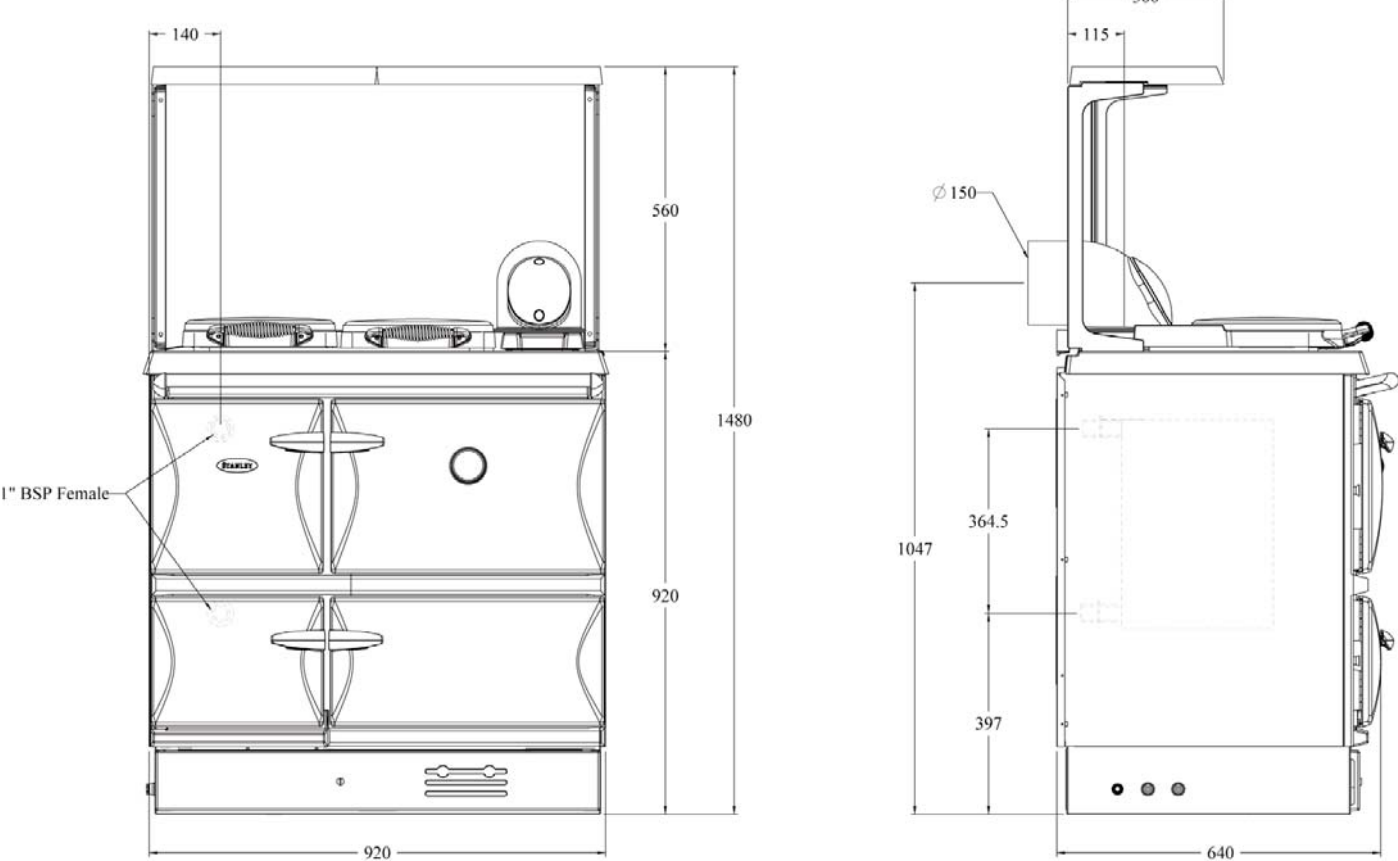

Note: Dimensions stated are in millimetres unless otherwise stated and may be subject to a slight +/- variation.

FEATURE	METRIC (mm)
Hot Plate	550W x 323L
Roasting Oven	390W x 310H x 406D
Simmering Oven:	390W x 220H x 406D

TECHNICAL DATA

FUEL:	28 Sec Kerosene
MAINS SUPPLY:	230-240V, 50Hz A.C.
I.P. PROTECTION DEGREE:	IP20
ELECTRICAL INPUT:	90 Watts
SUPPLY FUSE RATING:	3A
COOKER WEIGHT:	356 Kgs (783 lbs)
GROSS HEAT INPUT:	15.6 kW (53,355 Btu's)
NOZZLE:	DANFOSS 0.45 60° ES
PRESSURE SETTING:	115 p.s.i.
CO ₂ RANGE:	10.4 - 11.2%

ADDITIONAL TECHNICAL DATA FOR DHW MODELS:

MAX. DHW BOILER WORKING PRESSURE:	28 p.s.i.
TEST PRESSURE IN DHW BOILER:	40 p.s.i.
OPERATING TEMPERATURE LIMIT IN DHW BOILER:	96°C (194°F)
DHW BOILER CAPACITY:	10 Litres (2.2 gallons)
DHW BOILER MATERIAL:	3mm Stainless Steel
COOKER WEIGHT:	360 kg (790 lbs)
DHW BOILER OUTPUT:	3.8 kW (13,000 Btu's) (Continuous Running)

SCHEMATIC

Fig 1.

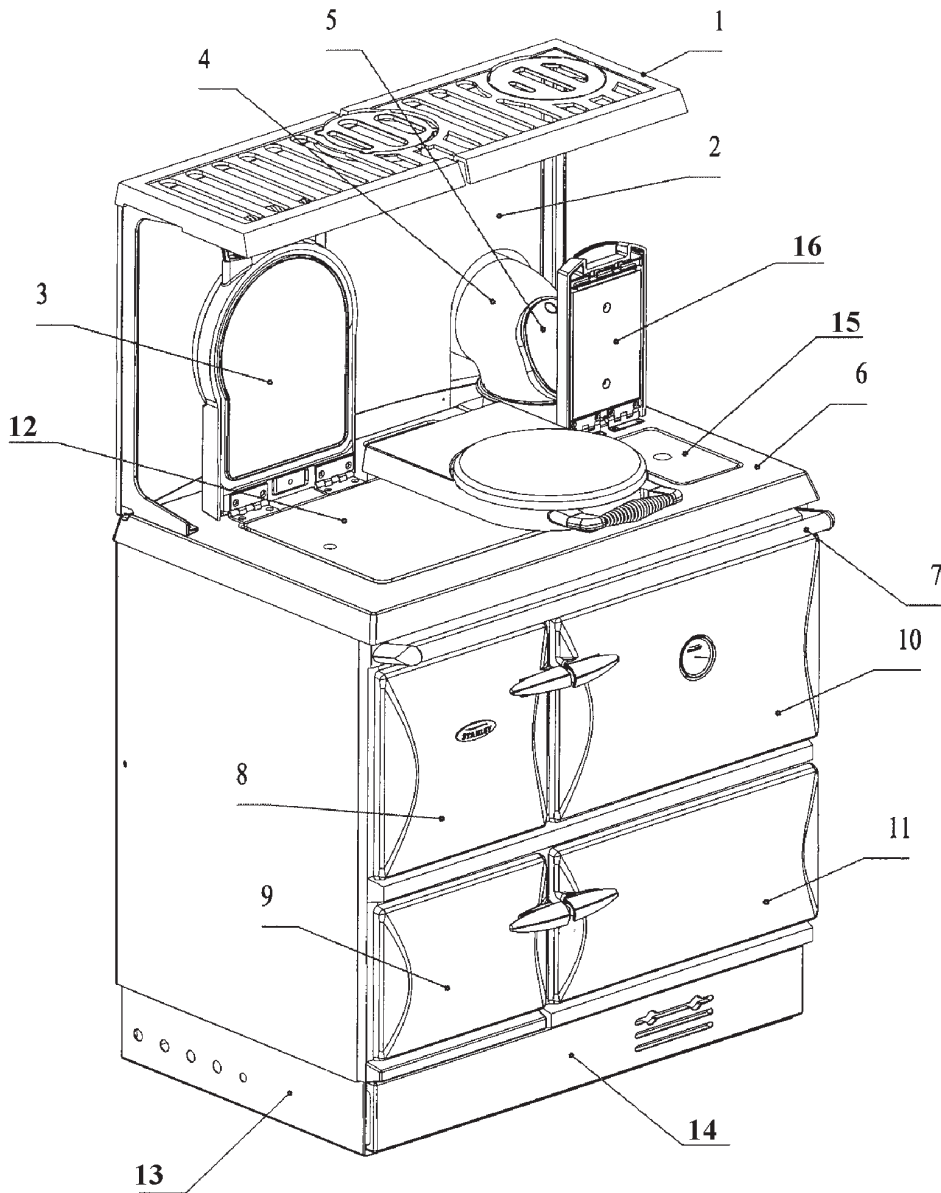

1. Platerack (to order)
2. Splashback (to order)
3. Hotplate Covers
4. 150mm (6") 90° Bend
5. Bend Cleaning Plate
6. Hob
7. Towel Rail
8. Firedoor
9. Burner Door
10. Main Oven Door
11. Simmer Oven Door
12. Hotplate
13. Base Frame
14. Pinth/Control Box Cover
15. Simmer and Cleaning Plate
16. Simmer Plate Cover



LOCATION

When choosing a location for this appliance you must have:

- Sufficient room for the installation (see clearances), a satisfactory flue (see flue system), and an adequate air supply for correct combustion and operation (see Ventilation and Combustion air supply).
- Adequate space for maintenance and air circulation.
- Solid floor or base of non-combustible material which is capable of supporting the total weight. (see Technical Data).

HEARTH CONSTRUCTION

When a non-combustible floor surface is not available then we recommend that the cooker be placed on a slab of pre-cast concrete 40mm (1¹/₂") deep or a slab of other insulating material. This hearth must extend 150mm (6") to either side of the appliance and 225mm (9") to the front.

ELECTRICAL SUPPLY

All wiring external to the appliance must conform to the current BS 7671, B.S. 7462, Safety Document 635 ETC: Part 1 Section 5.4.6. & the Electricity at Work Regulations. The cooker requires a 230V - 240V, 50Hz supply. Connection of this appliance to the mains supply must be through a moulded on plug top (with a 3A fuse) which is fitted to the appliance in accordance with EN 60335, Consumer Protection: SI 1994 No. 1768, (plug and sockets etc.) Safety Regulations 1994.

Always install in accordance with current local wiring regulations.

WARNING: THIS SUPPLY AND COOKER MUST BE EARTHED (Refer to B.S. 7430 : Code for Protection of Earthing).

Where there is a risk that the supply voltage could fall below 190 volts, a voltage sensitive device should be fitted to prevent the appliance from operating when the voltage is below 190 volts, so as not to endanger the installation. Primary fuse is located at rear of control box.

To isolate the appliance completely unplug from the mains socket. Always ensure that this socket is easily accessible and close to the appliance. Persons in charge of this appliance should be aware of this socket outlet position.

COOKER CLEARANCES

Minimum clearances to combustible materials:

- 6" (150mm) to either side
- 2" (50mm) to rear
- 36" (915mm) above
- 48" (1220mm) to front (See figs 2 & 3)

Fig.2

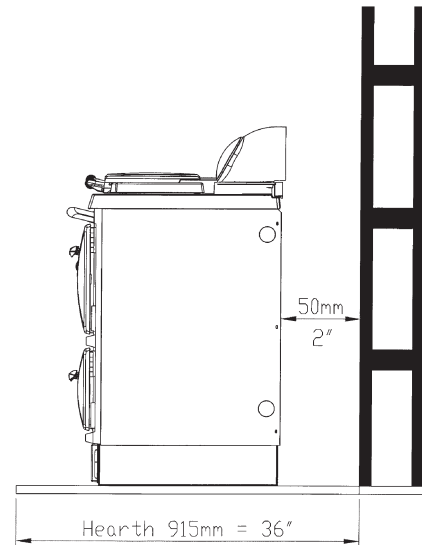
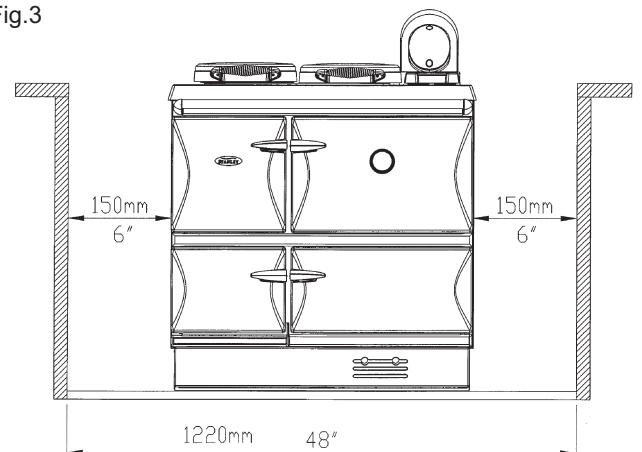

Fig.3



Minimum clearances to non-combustible materials:

- 1" (25mm) to either side.
- Reduced to 15mm stops at rear
- 36" (915mm) above
- 48" (1220mm) to front (see figs.4&5)

Fig.4

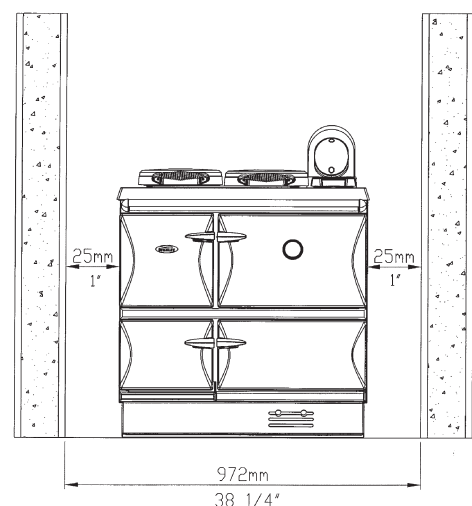

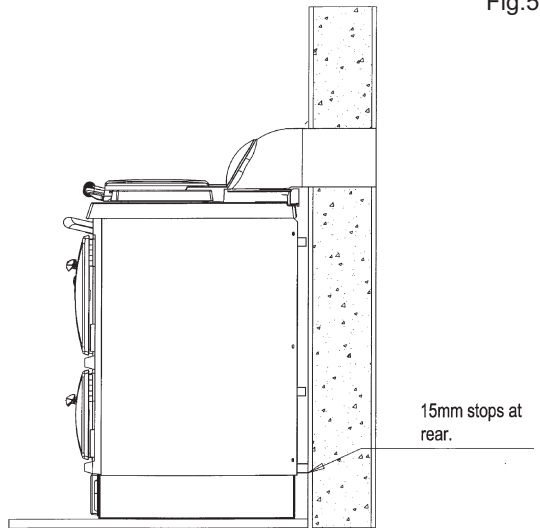

Fig.5

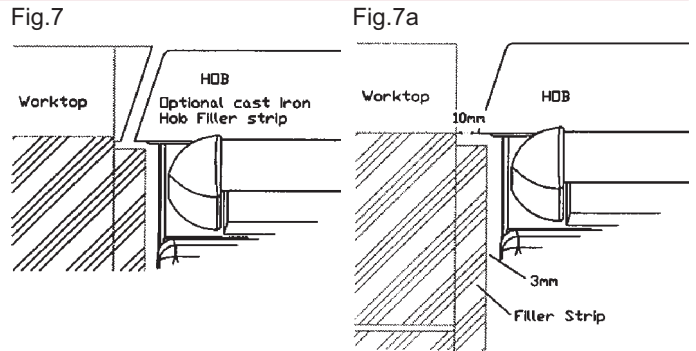

Fig.7

Fig.7a

REDUCED CLEARANCES

Where the flue passes through a combustible material a twin wall solid packed insulated chimney connector must be used and must come flush with the outer surface of the material and run all the way to the masonry chimney or to the point of termination of the factory made chimney. (see Fig. 6)

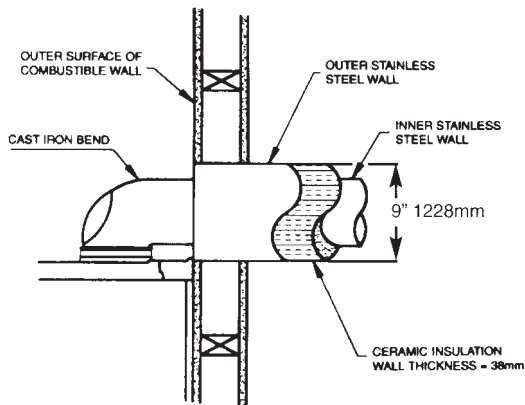

Fig.6

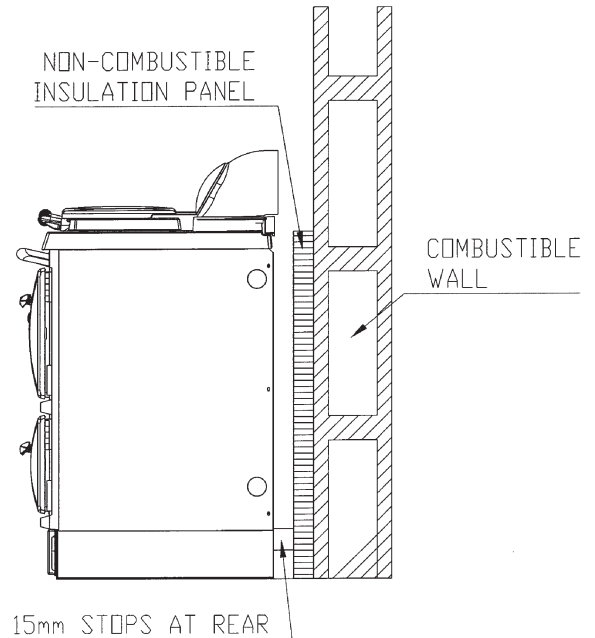
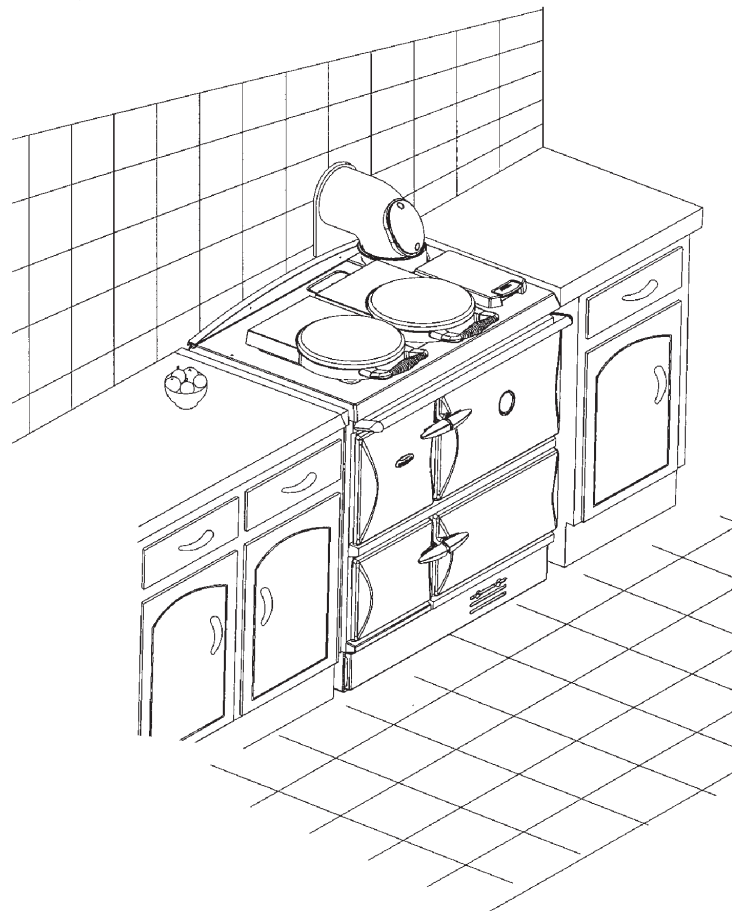

Fig.8

If the cooker is to be installed against combustible material (e.g. cabinetry or wall panelling) a panel of 12mm ($\frac{1}{2}$ ") thickness non-combustible insulation board the size of the appliance must be fitted between the cooker and the combustible material. The insulation board used must not contain asbestos or ceramic. (See Figs. 7 & 8)

The clearances for non-combustible materials can then be observed (see Fig.4)

An optional hob filler strip can be fitted between the Stanley and adjacent units. Refer to fig.7.



PRE-INSTALLATION CHECK

Before installing your cooker, check that the chimney is clean and clear of obstructions. Cracked brickwork and leaking joints should be made good.

IT IS RECOMMENDED TO CONNECT TO A FLUE OR FLUE LINER OF 125MM (5").

Fig. 10

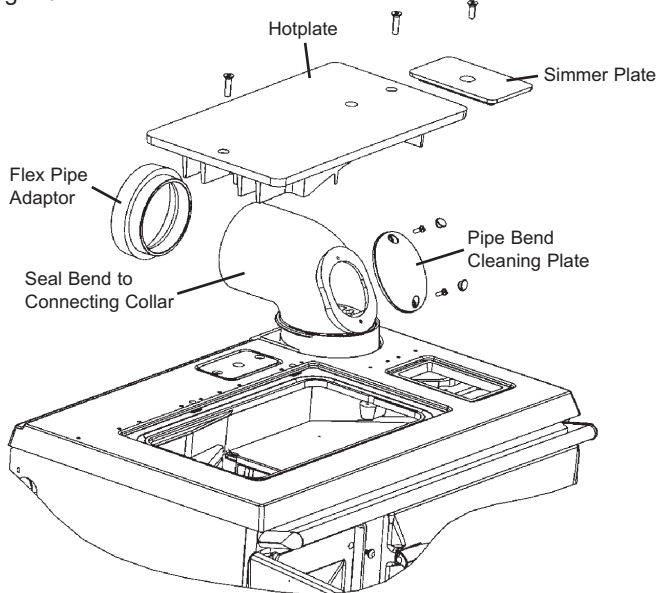

FLUES

The chimney and flue pipes intended for use with this appliance should be mechanically robust, resistant to internal and external corrosion, non-combustible, and durable under the conditions to which they are likely to be subjected.

Flues require a suitable external terminal which should be designed to permit the easy exit of combustion products whilst providing protection against the ingress of rain, birds and other foreign matter into the system. Flue pipes and accessories such as clips and stays should not be made of unprotected mild steel or other material which is likely to corrode.

Where flue piping passes through a closure plate with a sliding door, ensure that the pipe continues up and is ultimately connected to the flue liner and well sealed with fire cement.

Do not connect to a chimney serving another appliance. Chimneys wholly constructed of single skin pipe are not recommended under any circumstances. Due to their inability to retain heat such chimneys will inevitably give rise to the formation of condensation.

The outlet on the appliance is 6" (150mm) diameter. The product is supplied with a reducer to reduce the diameter of the chimney/flue from 6" (150mm) to the required 5" (125mm). If using enamelled pipes or bends it is permitted to use 6" (150mm) diameter up to a length of 6ft (1.8 meter) from the outlet of the

cooker. Following these, the diameter of the chimney / flue should be reduced to 5" (125mm).

Flue Liner

Fig.11

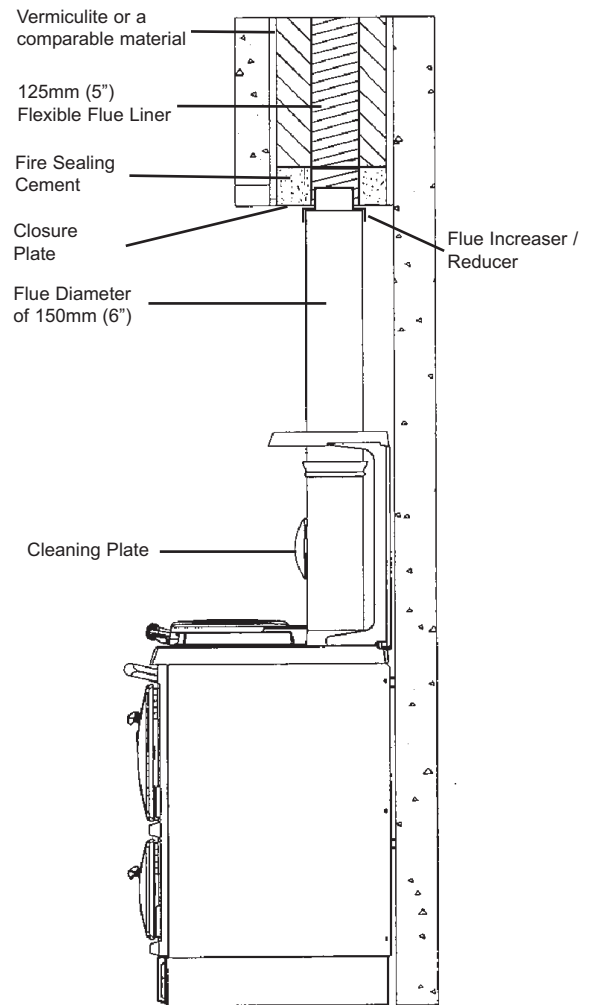

Note: Fill voids and area around liner with vermiculite or a comparable approved material. (See Fig. 11 & 12)

CHIMNEY'S

Generally the most effective chimney for oil is one that is straight, avoid offsets and terminate with a straight sided pot.

Flue greater than 125mm (5") Diameter

Fig. 12

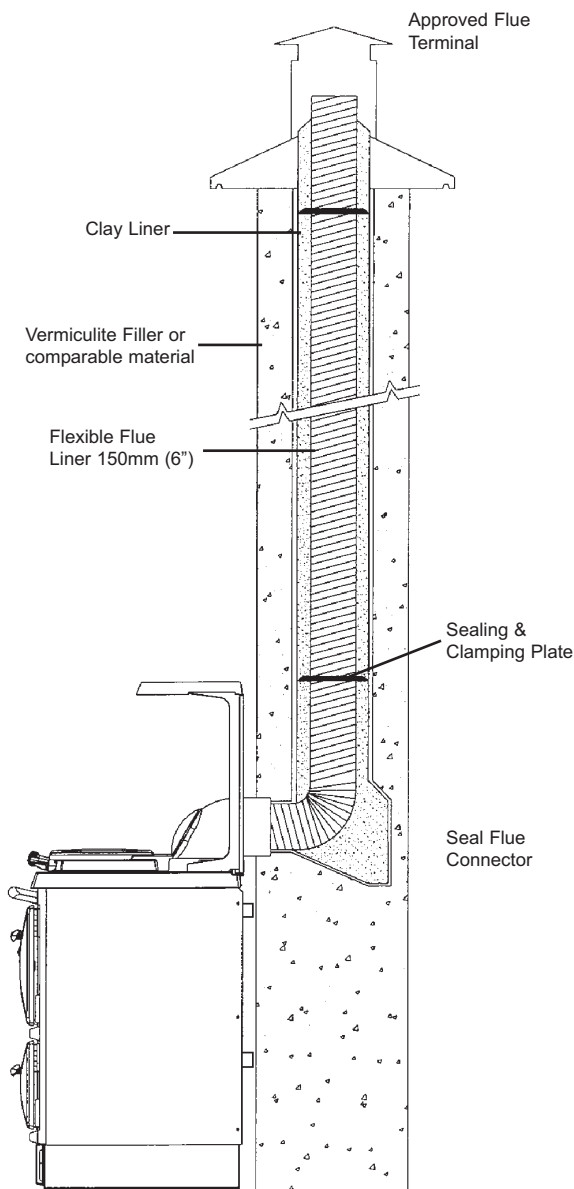

SEALING

This cooker and flue system operate under a positive pressure, it is essential that all flue joints are tightly sealed against flue gas leakage and tested accordingly (see Fig. 11 & 12).

There is a flue pipe collar available which surrounds the flue pipe where it meets the wall, giving a tidier finish to a tiled background (see fig. 9). The flue pipe collar is available as an optional extra, to order.

Fig.13

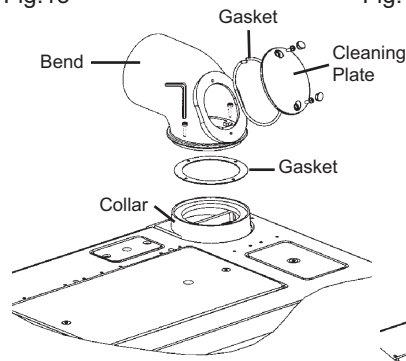
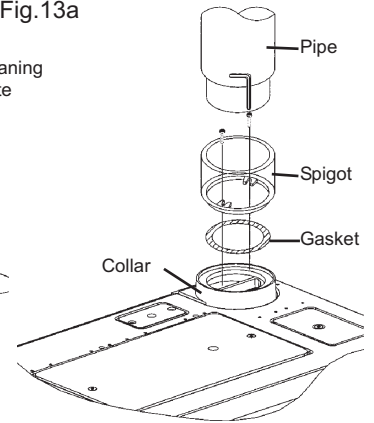

Fig.13a



Refer to Flue Assembly Instructions sheets.

FLUE HEIGHT

The flue must be high enough 4.5 mts. (15ft) minimum measured vertically from the appliance outlet to the top of the flue terminal, to allow the flue gases to vent into the clear air, away from the turbulence that may be caused by roof structures, other chimney stacks, etc. The terminal position should be in accordance with B.S. 5410 and the current Building Regulations.

If it is necessary to offset the chimney the recommended angle is 60° to the horizontal and the statutory minimum is 45° (see fig. 14).

Note: Never connect to a chimney or flue system serving another appliance.

Fig.14

Offset using prefabricated bends

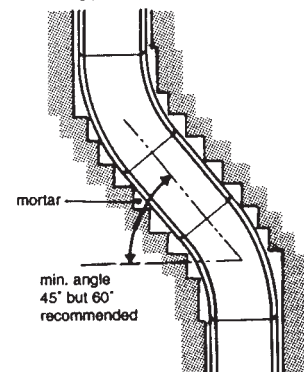

CONNECTIONS

A cast iron 90° bend with cleaning door is supplied with the cooker, along with a cast iron spigot for connection to a vertical flue pipe. A vertical cast iron outlet pipe with cleaning door is available to order. A flexible flue adaptor is supplied, this is to connect the cooker bend or straight pipe to the chimney liner.

Note: Maximum horizontal length should not be more than 300mm (12") where the appliance spigot or flue pipe protrudes into the chimney, care should be taken to ensure that it does not block the chimney.

ALL FLUE CONNECTIONS MUST BE THOROUGHLY SEALED.

Blocked chimneys are dangerous, keep chimneys and flueways clean, read the operating instructions.

STANLEY CAST IRON PIPES AND BENDS ARE HIGHLY RECOMMENDED FOR INTERIOR USE.

SUITABLE MATERIALS

- * Mineral Fibre cement pipes conforming to B.S. 7435.
- * Sheet metal conforming to B.S.4076.
- * Insulated metal chimneys conforming to B.S.4543 and B.S. 5410 (a galvanised finish is not suitable).
- * Clay flue linings conforming to B.S. 1181.
- * Pre-cast concrete chimney blocks, incorporated into the building structure. It is particularly important that the correct connection block be provided at the base of the flue, B.S. 3572.
- * Cast Iron or acid resistant vitreous enamel lined mild steel to B.S. 41.

FLUE CLEANING

The flue pipe must be fitted with a cleaning plate. The flue must be inspected annually and cleaned when necessary.

USE OF EXISTING FLUES AND CHIMNEYS

When connecting to an existing chimney it is necessary to line the flue using approved 125mm (5") rigid or flexible stainless steel flue liner.

An existing flue pipe or chimney that has proved to be satisfactory when used for solid fuel can normally be used for this appliance provided that its construction, condition and dimensions are acceptable. Flues that have proved to be unsatisfactory, particularly with regard to down draught, must not be considered for this appliance until they have been examined and any faults corrected. If there is any doubt about an existing chimney, a smoke test to B.S. 5410 should be carried out.

Before connecting this appliance to a chimney or flue pipe which has previously been used with another fuel, the chimney or flue pipe must be thoroughly swept and lined accordingly.

All register plates, restrictor plates, damper etc. which could obstruct the flue at a future date must be removed before connecting this appliance.

Where a chimney is not to be lined a suitable void should be provided at the base to contain any debris which might fall from inside the chimney, so as to prevent that debris from obstructing the appliance flue outlet. (Removal of debris should be facilitated by the provision of an access door). The void

should have a depth of not less than 250mm (10") below the appliance connection.

The combustion products will have a descaling effect on hardened soot deposits left from burning solid fuels.

ALTHOUGH THE CHIMNEY MAY HAVE BEEN CLEANED OF LOOSE SOOT PRIOR TO INSTALLATION, IT IS IMPERATIVE THAT THE CHIMNEY IS INSPECTED FOR SCALED SOOT PARTICLES AFTER THE FIRST MONTH OF OPERATION AND ANY LOOSE MATERIALS REMOVED TO AVOID BLOCKAGE.

DRAUGHT REQUIREMENTS

While inadequate draught can seriously effect the efficient operation of the appliance, chimneys over (5.4m) 18ft. or houses built on high ground can experience excessive draught, a steady draught of between 1mm (0.04") and 1.5mm (0.06") W.G. is required for satisfactory operation.

FLUE LINERS

Chimney's lined with salt glazed earthenware pipes are acceptable if the pipes comply with BS 1181 and must be 125mm (5"). When lining an existing chimney, a liner approved to BS 4543, Parts 1, 2 & 3 should be used. The liner should be secured at the top and bottom by using closure/ clamping plate firmly sealed and secured and an approved terminal used at the top.

It is essential that every flue system be inspected and tested by a competent person for its correct effectiveness, to ensure that the combustion products are completely discharged to the outside atmosphere.

FACTORY MADE INSULATED CHIMNEYS

Factory-made insulated chimneys should be constructed and tested to meet the relevant standards and recommendations given in:

- * B.S. 7566 - Installation of factory-made chimneys conforming to B.S. 4543 for domestic appliances.

Part 1: Method of specifying installations design information.

Part 2: Specification for installation design.

Part 3: Specification for site installation.

Part 4: Recommendation for installation design and installation.

VENTILATION AND COMBUSTION AIR REQUIREMENTS

1. It is imperative that there is sufficient air supply to the burner of the cooker in order to support correct combustion.
2. The air supply to this appliance must comply with BS 5410 Part 1.
3. The minimum effective air requirement for this appliance is 65cm^2 . When calculating combustion air requirements for this appliance use the following equation: 550mm^2 per kW of maximum rated output above 5kW. These requirements are illustrated in OFTEC Technical Book No. 3 & B.S. 5410.
4. If there is another appliance using air fitted in the same or adjacent room, it will be necessary to refer to B.S. 5410 to calculate the additional air supply.
5. All materials used in the manufacture of air vents should be such that the vent is dimensionally stable and corrosion resistant.
6. The effective free area of any vent should be ascertained before installation. The effect of any gauze or screen should be allowed for when determining the effective free area of any vent.
7. Air vents direct to the outside of the building should be located so that any air current produced will not pass through normally occupied areas of the room.

An air vent outside the building should not be located less than the dimensions specified within the Building Regulations (See Technical Data) from any part of any flue terminal. These air vents must also be satisfactorily fire proofed in accordance with the current Building Regulations.
8. Air vents in internal walls should not communicate with bedrooms, bedsits, toilets, bathrooms or rooms containing a shower.
9. Air vents traversing cavity walls should include a continuous duct across the cavity. The duct should be installed in such a manner as not to impair the weather resistance of the cavity.
10. Joints between air vents and outside walls should be sealed to prevent the ingress of moisture. Existing air vents should be of the correct size and unobstructed for the appliance in use.
11. If there is an air extraction fan fitted in the room or adjacent rooms where this appliance is fitted, additional air vents will be required to alleviate the possibility of spillage of products of combustion

from the appliance/flue while the fan is in operation. (Refer B.S. 5410).

12. Where such an installation exists, a test for spillage should be made with the fan or fans and other burning appliances in operation at full rate. (i.e. extraction fans, tumble dryers) with all external doors and windows closed.
13. If spillage occurs following the above operation, an additional air vent of sufficient size to prevent this occurrence should be installed. As a general guide an extra 50cm^2 of air vent free area will be sufficient for most situations.

OUTSIDE AIR CONNECTION

This appliance may be connected direct to the outside of the house for its air supply.

1. If this option is used a special kit is available to order.
2. Additional combustion air is not required as indicated in B.S. 5410.
3. Remove air inlet plate on front right hand side, replace it with the blanking plate located at back left hand side (see fig.15).
4. The left hand side of the appliance must remain open to provide cool air for the programmable timer.
5. Connect the optional 125mm (5") spigot to the base. (see fig. 16)
6. To connect this cooker to an outside air supply use the special order kit.
7. Air inlets traversing cavity walls should include a continuous duct across the cavity. The duct should be installed in such a manner as not to impair the weather resistance of the cavity. This duct should be satisfactorily fire proofed in accordance with the current Building Regulations.
8. Joints between air vents and outside walls should be sealed to prevent ingress of moisture.

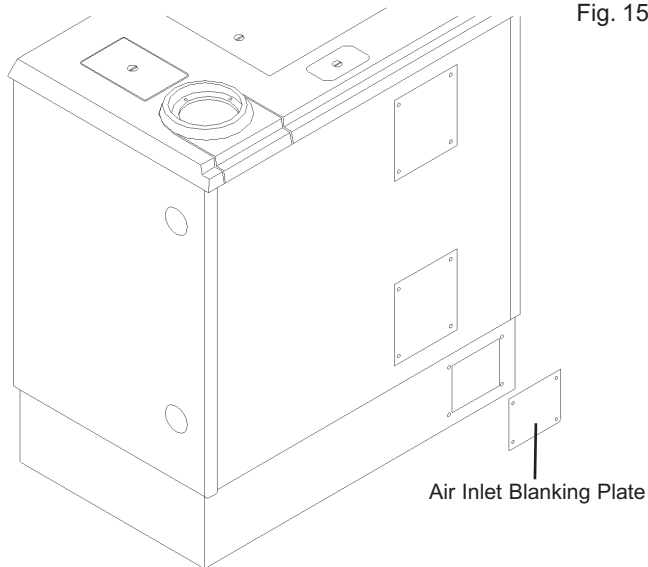

Fig. 15

Air Inlet Blanking Plate

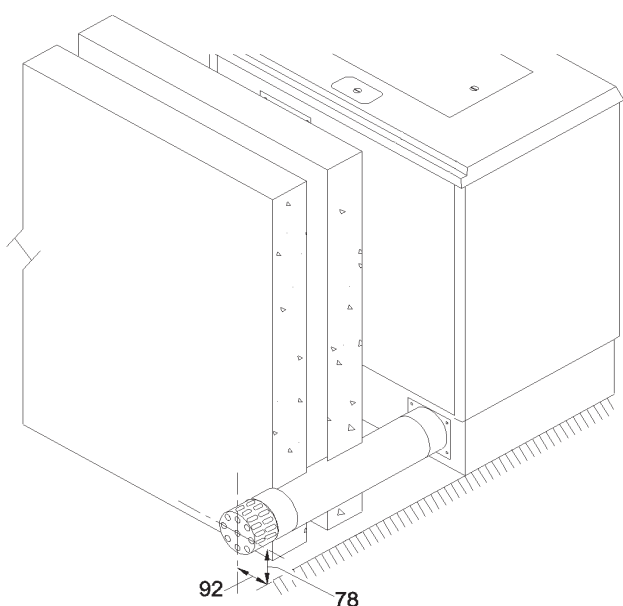
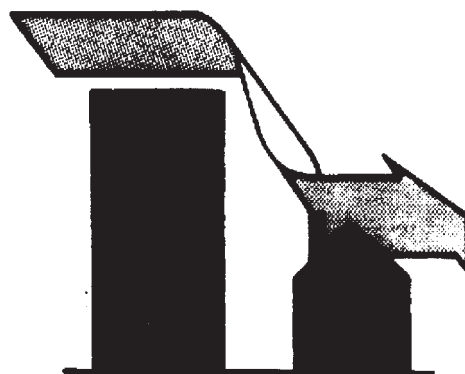

Fig. 16

DOWN DRAUGHTS

However well designed, constructed and positioned, the satisfactory performance of the flue can be adversely affected by down draught caused by nearby hills, adjacent tall buildings or trees. These can deflect wind to blow directly down the flue to create a zone of high pressure over the terminal. A suitable anti-down draught terminal or cowl will usually effectively combat direct down blow but no cowl is likely to prevent down draught due to a high pressure zone. Ensure that any cowl used will not restrict the flue exit or cause excessive back pressure (See fig. 17) Refer to BS 5410.

Fig. 17



Direction of Wind →

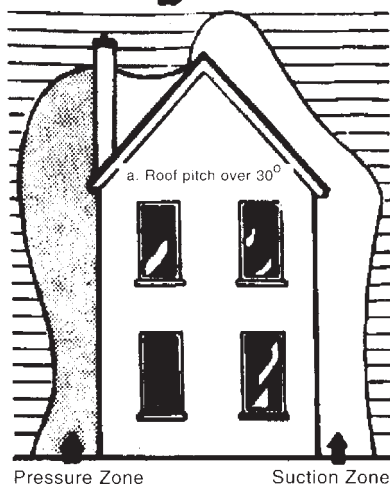

a. Roof pitch over 30°

Pressure Zone

Suction Zone

Direction of Wind →

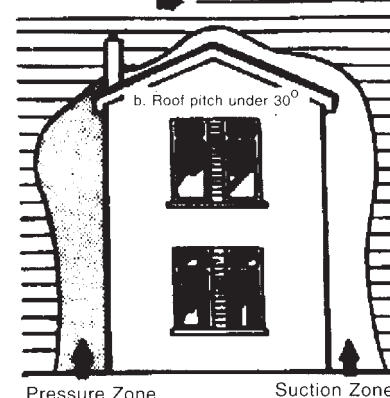

b. Roof pitch under 30°

Pressure Zone

Suction Zone

Direction of Wind →

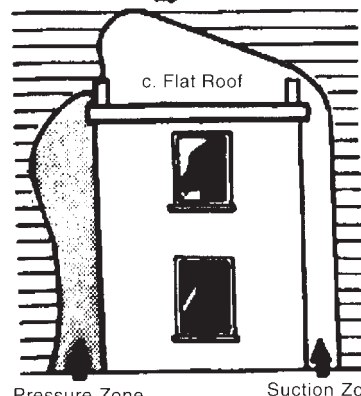

c. Flat Roof

Pressure Zone

Suction Zone

**WIRING DIAGRAM - MECHANICAL
CLOCK**

The following diagrams illustrate the different types of central heating systems to which this appliance can be connected, but are not to be used as working drawings.

Fig.18

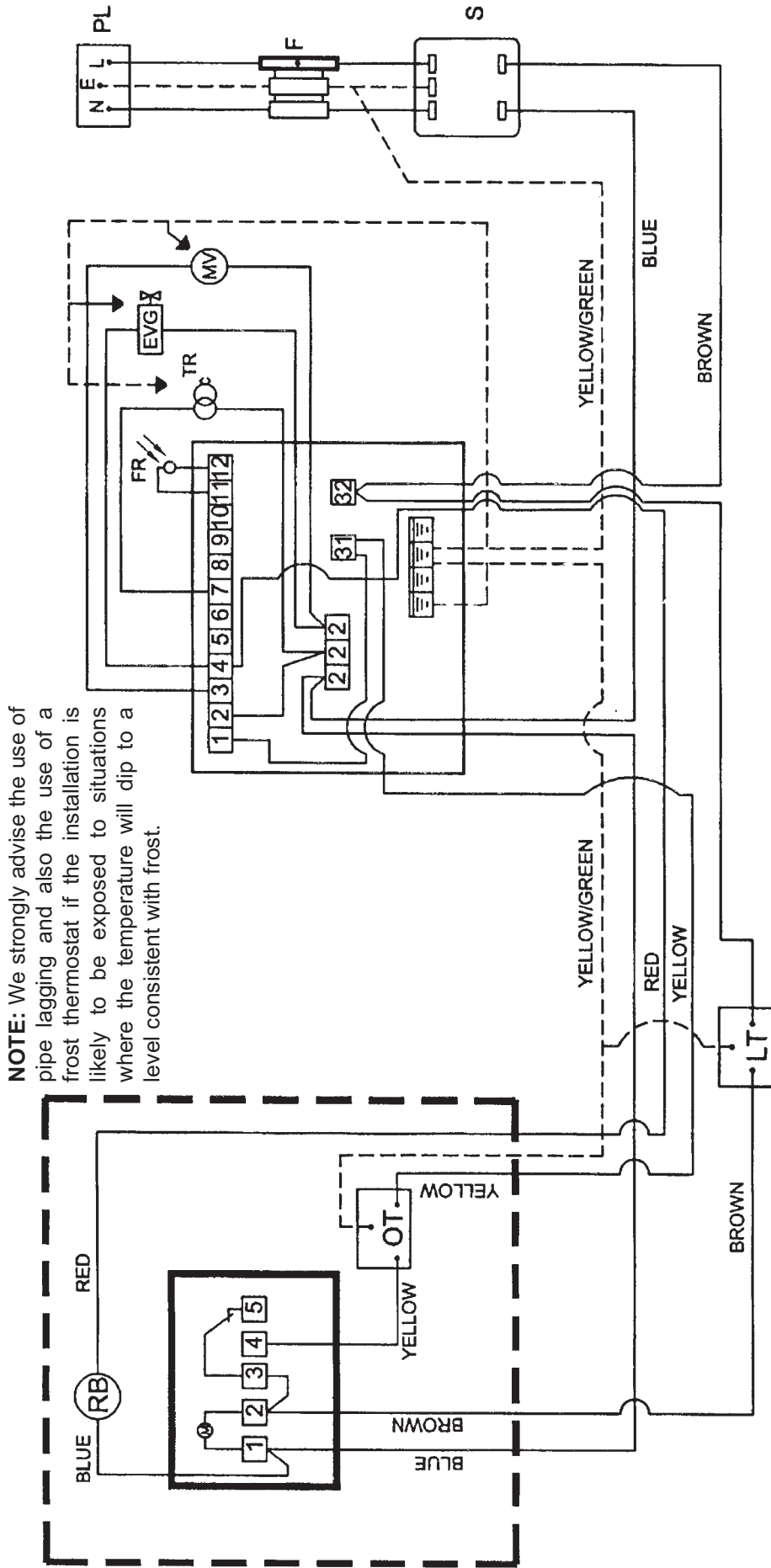

NOTE: We strongly advise the use of pipe lagging and also the use of a frost thermostat if the installation is likely to be exposed to situations where the temperature will dip to a level consistent with frost.

PL - 13 AMP PLUG TOP
 F - FUSE BLOCK COMPLETE WITH 3 AMP FUSE
 EVG - SOLENOID VALVE
 TR - TRANSFORMER
 MV - BURNER MOTOR
 FR - PHOTOCELL

OT - OVEN THERMOSTAT
 LT - HIGH LIMIT THERMOSTAT
 RB - RUNNING LAMP
 S - SUPPRESSER

CYC - STAT:
 Remove link between Terminal 1 and Terminal 31. Connect cyc - stat on to Terminals 1 & 31.

WIRING DIAGRAM (DIGITAL TIMER) Fig. 19

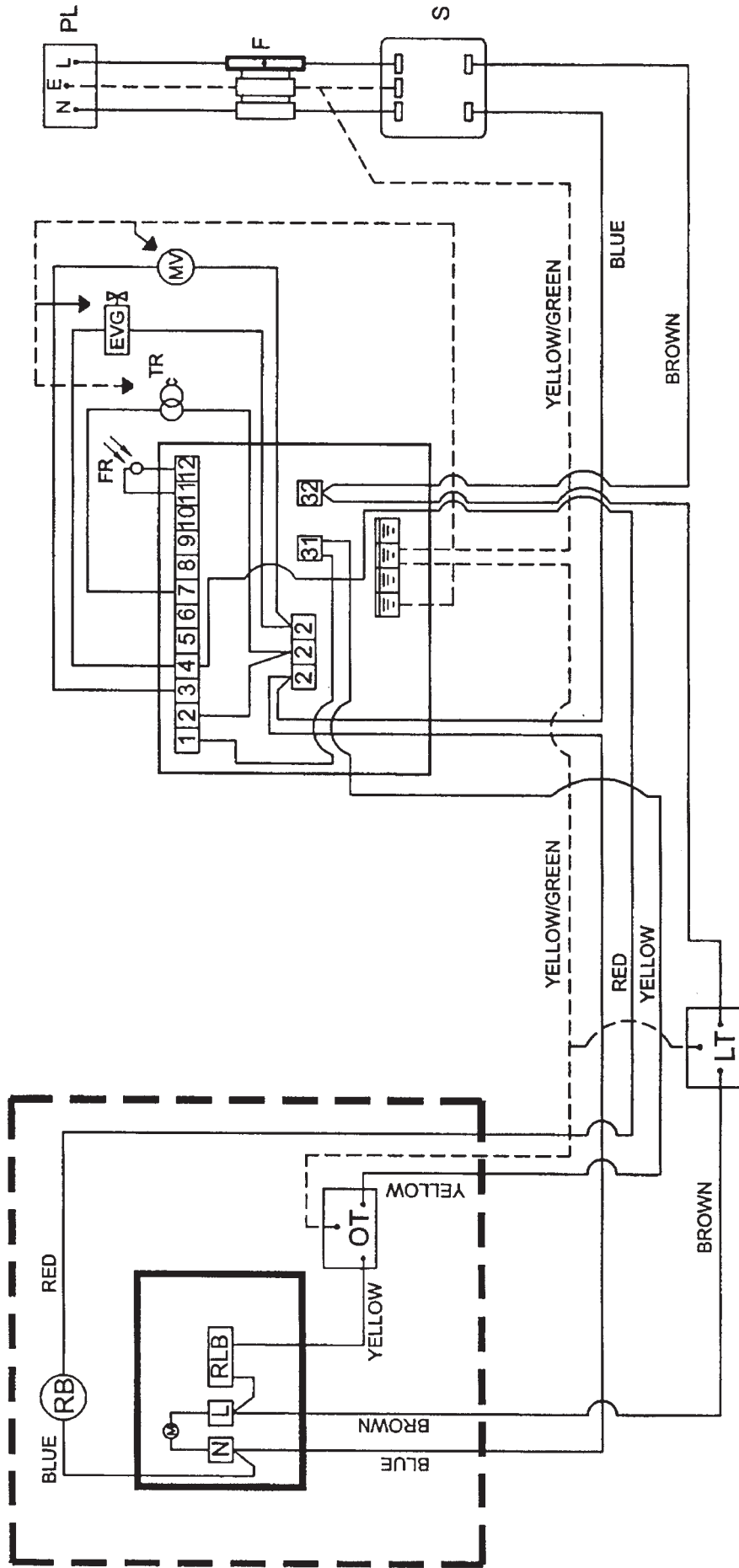

PL - 13 AMP PLUG TOP
F - FUSE BLOCK COMPLETE WITH 3 AMP FUSE
EVG - SOLENOID VALVE
TR - TRANSFORMER
MV - BURNER MOTOR
FR - PHOTOCELL

OT - OVEN THERMOSTAT
LT - HIGH LIMIT THERMOSTAT
RB - RUNNING LAMP
S - SUPPRESSER

CYC - STAT:
Remove link between Terminal 1 and Terminal 31. Connect cyc - stat on to Terminals 1 & 31.

DOMESTIC HOT WATER SYSTEM (DHW MODEL ONLY)

SYSTEM

The DHW Model must be connected to a fully pumped system.

Care should be taken to ensure that the domestic hot water installation is correctly installed and that it complies with all relevant codes of practice. If this appliances is being connected to an existing system, it is strongly recommended to check the following:

- (a) That the system is sound.
- (b) That the pipe work is adequately insulated.
- (c) Check that the system is fitted with a circulation pump and a pipe stat and that both are operating satisfactorily.
- (d) Are there any modifications necessary to make the domestic hot water system more efficient.

SAFETY VALVE

A non-adjustable 3 bar safety valve must be fitted to the primary flow pipe adjacent to boiler connection ensuring that any discharge will not create a hazard to occupants or cause damage to electrical components or property.

NOTE: We strongly advise the use of pipe lagging and also the use of a frost thermostat if the installation is likely to be exposed to situations where the temperatures will drop to a level consistent with frost.

Only competent personnel should be employed to carry out any work on your domestic hot water system.

It is important that no external control devices e.g. economisers are directly fitted to this appliance unless covered by these installation instructions or agreed with the manufacturer in writing. Any direct connection of a control device not approved by the manufacturer could make the guarantee void.

PIPE FITTINGS

Materials used for installation work should be resistant, sound and should conform to the current editions of the following or there equivalent:

- 1.1 Ferrous Materials
 - B.S. 4127: Stainless Steel Tubes
 - B.S. 1387: Steel Tubes
 - B.S. 1740: Steel Pipe Fittings
 - B.S. 6956: Jointing Materials

- 1.2 Non-Ferrous Materials
 - EN 29453: Soft Solder Alloys
 - B.S. 864: Compression Tube Fittings
 - B.S. 2871 & B.S. EN 1057 Copper and Copper Alloys

DIRECT DOMESTIC CYLINDER

A 227 Litre (60 Gallon) direct domestic cylinder can be connected to this cooker using copper or stainless steel 28mm O.D. (1") flow & return pipes. We recommend that the cylinder is lagged along with the pipework. (See Fig.20)

Fig.20

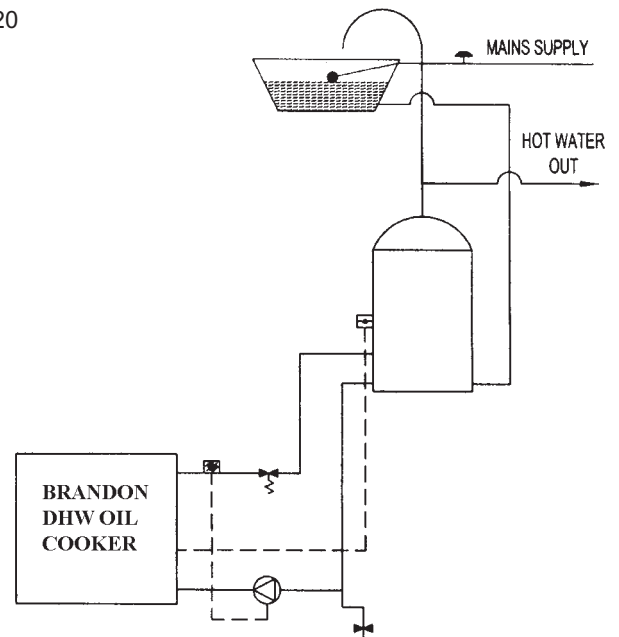

INDIRECT DOMESTIC CYLINDER

A 227 Litre (60 Gallon) indirect domestic cylinder can be connected to this cooker using copper or stainless steel 28mm O.D (1") flow and return pipes. We recommend that the cylinder is lagged along the pipework (See Fig. 21)

Fig.21

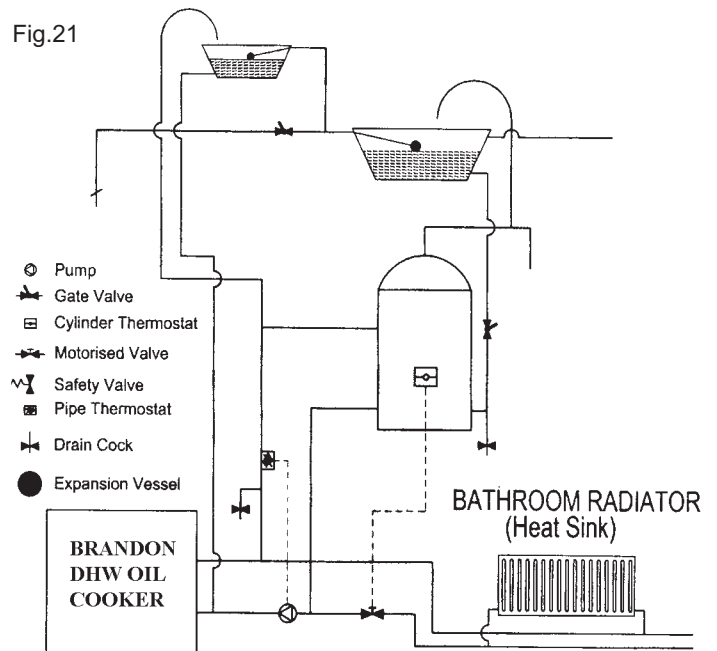

NOTE: Copper cylinder should be “finned-coil” type with minimum capacity of 210 litres to B.S. 1566 & B.S. 699.

Cylinder thermostat set @ 60° and connected to motorised valve (see Fig.21).

INDIRECT SYSTEM ONLY

To off-load excess hot water generated during long cooking periods, it may be necessary to install a heat sink radiator.

We strongly recommend the fitting of a circulating bronze pump on the return pipe to the boiler, controlled by a pipe thermostat fitted on the flow pipe within 6” (150mm) of the appliance.

PIPE THERMOSTAT

The fitting of a pipe thermostat to the common flow pipe within 150mm (6”) of the cooker is recommended in order to activate the water circulation pump when the boiler reaches 60°C. This will ensure that the return temperatures are maintained and allow the pump to ‘run on’ to transfer any residual heat to prevent possible overheating.

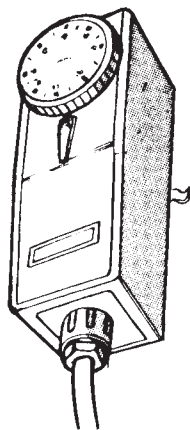

Fig.22

NOTE: In line water conditioners fitted to the cold mains supply both of chemical and magnetic type are suitable for use with DHW cooker.

FUEL INSTALLATION

OIL STORAGE TANKS

Oil storage tanks made of steel and all connecting equipment (eg: filling pipes and vent pipes) should comply with B.S. 799 Part 5. Galvanised steel must not be used. Polyethylene (Plastic) tanks should comply with OFTEC standard OFS T100 and or equivalent. Oil should never be stored in translucent plastic containers.

An isolating valve should be fitted at the tank outlet, in a accessible position so that the oil supply to the appliance can be shut off if required. This isolating valve must be of a type suitable for use with oil. (See Fig. 23, 24, & 25).

In order to enable the sediment and water to be removed from tanks a drain valve should be fitted.

Oil storage tank support must be carried out in accordance with the tank manufactures recommendations. Tanks should be located in the most unobstructive position possible having taken safety, filling, maintenance and the need, if any, to provide a head of oil for the burner into consideration.

FUELS

THE RECOMMENDED FUEL IS KEROSENE 28 SECOND VISCOSITY FUEL OIL.

FUEL SUPPLY LINE

The oil supply line from the oil storage tank to the appliance should be of an approved and suitable pipe with a minimum internal diameter of 9mm (3/8”) and connected to the oil inlet connection located at the cooker left hand side.

Oil supply pipes are normally run in annealed copper tube complying to B.S. E.N. 1057. It can be obtained in coil or half hard form for use with bending machines. This pipe can also be obtained with protective plastic sheathing applied. Fittings for copper pipe should be compression of the flared manipulative type to B.S. : 864: Part 2 1983. Steel pipes complying with B.S. 1387: 1985, if used, must be protected from corrosion. Galvanised pipe and fittings must not be used.

Screwed joints must only be made with tapered threads complying to B.S. 1740: Part 1: 1971.

Jointing materials must be of types intended for use with oil fuel. Special petroleum - resisting compounds and PTFE tape are suitable. External pipes should preferably be run with a continuous rise towards the direction of flow, so that one can be vented off. It is important to avoid high points which could cause air locks.

Exposed lengths of oil supply pipe must be properly supported by purpose made clips securely fixed in place. Metal clips formed so as to hold the pipe on to a saddle are preferred. Consideration should be given to avoiding routes which expose the pipe to severe chilling which could cause freezing of the oil. Where pipes are buried, they must be protected from accidental damage. The use of joints underground should be avoided if at all possible. If joints have to be fitted in pipes laid below ground, access to them must be provided.

An oil filter (5 - 10 micron) and stop valve must be fitted to the fuel feed line and located near the supply tank and facilities should be provided to enable it to be serviced without draining down the

oil supply system. (See Figs, 23, 24, & 25).

At the point where the oil line enters the building, the oil line must be fitted with an approved remote acting fire valve, which meets the requirements of B.S. 5410 : Part 1, fitted with the appropriate length of capillary. The heat sensing phial of the fire valve must be fitted to the clip provided in the burner compartment. It is absolutely essential that the fire valve is located externally and is as close as possible to the appliance. For existing installations where the oil supply are built into the structure internally, the remote acting fire valve should be fitted where the oil supply line is first exposed internally. This type of layout is not recommended for new installations.

When gravity feed is used (the most common) the minimum head should not be below 1 meter (3'3") and the maximum head should not exceed 6.5 meters (21' 3").

NOTE: The pump is factory set for a single pipe installation.

The oil line is to be connected to the flexible oil hose attached to the burner. Push the flexible oil hose through the grommet on the left hand side of the appliance.

SINGLE PIPE SUPPLY SYSTEM: BOTTOM OF OIL STORAGE TANK ABOVE BURNER (See fig.23)

Single pipe supply system: Tanks servicing this appliance by means of a single pipe need to be positioned so that they will apply the minimum head required 1 meter (3' 3") of oil to the burner when the fuel level is at its lowest point.

Refer to B.S. 5410 to calculate the additional head requirement relating to pipe length and size.

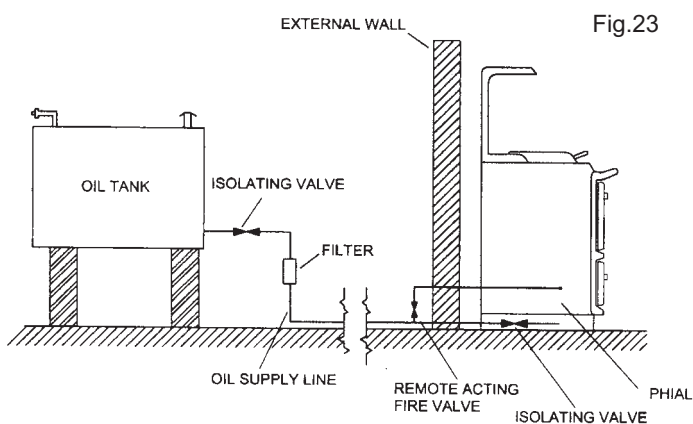

Fig.23

TWO PIPE SUPPLY SYSTEM: (See fig.24) BOTTOM OF OIL STORAGE TANK BELOW OR LEVEL WITH BURNER

If the tank base is below the level at which the

gravity feed to the burner can be maintained a two pipe oil supply system may be adopted. (See fig. 24). The non-return valve in the supply line of the two pipe system is required to prevent oil running back from the burner and unpriming the oil pump.

The non-return valve in the return line is only required if the top of the tank is above the burner. Its purpose is to prevent oil running back through the burner during maintenance.

Fig.24

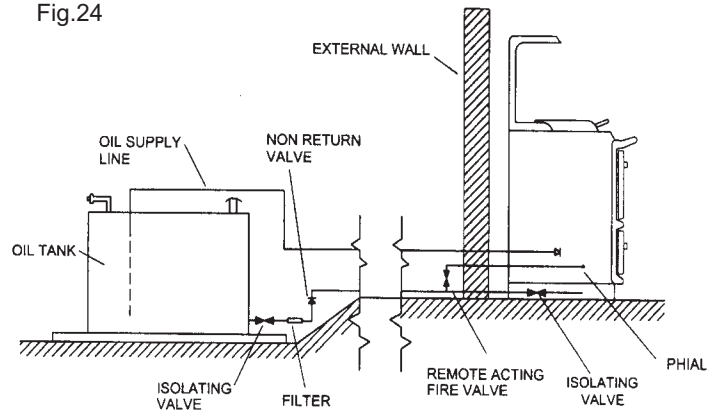

SINGLE PIPE SYSTEM: WITH DE-AERATION DEVICE BOTTOM OF OIL STORAGE TANK BELOW OR LEVEL WITH BURNER. (see fig. 25):

This system can be used where the tank base is below the level at which gravity feed to the burner can be maintained and the burner incorporates an oil pump. The chamber is fitted close to the burner and is linked to the tank by a single pipe, thus saving the return pipe required by the two pipe system as described previously. Any air in the oil brought up from the tank is bled off in the de-aeration chamber.

De-aeration chambers must always be installed externally to buildings because they emit small quantities of vapour. The chamber is connected to the oil pump in the burner of the appliance by a normal two pipe loop.

These requirements are fully explained within the following documents:

- * B.S. 5410: Part 1: Code of Practice for Oil firing installations up to 45 kW output capacity for space heating and hot water supply purposes.
- * OFTEC - Technical information Book Three. Installation requirements for oil fired boiler and oil storage tanks.
- * The Building Regulations Part J: Ireland Part F Section 4 Scotland and Part L Northern Ireland.
- * The Building Regulations Part J: England & Wales.

Fig.25

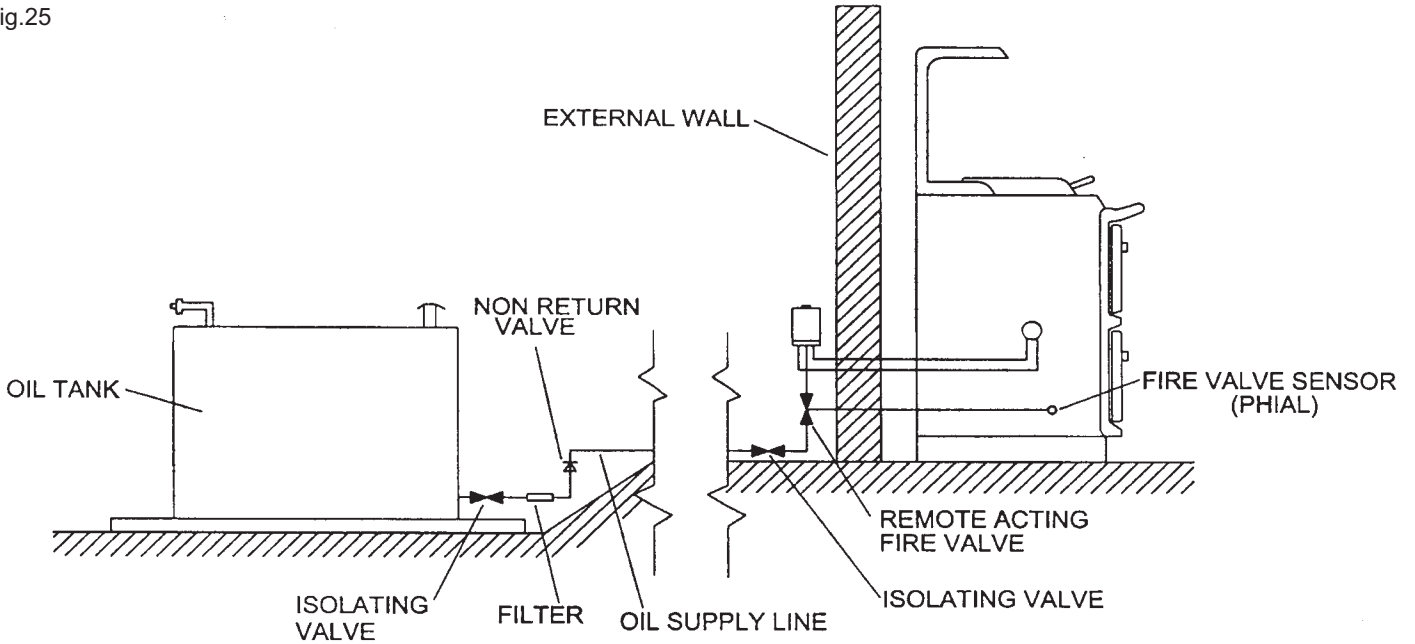

COMMISSIONING CHECKS

1. Check all items from packaging are removed from ovens and the shelves are properly fitted.
2. Check that electrical wiring is correct.
3. Check that the cylinder and pipework are purged of air and full of water with a suitable safety valve fitted.
4. Check that the pipe stat is fitted as close as possible to the boiler outlet.
5. Check that all valves in the oil line are open and that the filter is purged of air. Check that the fire valve is open.
6. Turn on the electrical supply and check that the time switch and thermostat are calling for heat. Burners should now fire.
7. With fuel supply off, switch on the burners.
8. Complete the start sequence to lockout (8 seconds) for the burner observing the correct operating functions.
9. Ensure the pump is purged of air. Check pump pressure with a calibrated pressure gauge and adjust if necessary to 115 p.s.i. (see fig.26).
For further information refer to Technical Data on page 4.
10. Re-instate fuel supply and switch on the burner to ensure that it fires correctly.
11. After the appliance has achieved its operating temperature, carry out a flue gas analysis. (See fig.27).
12. Check for smoke and flue draught reading.

Fig.26

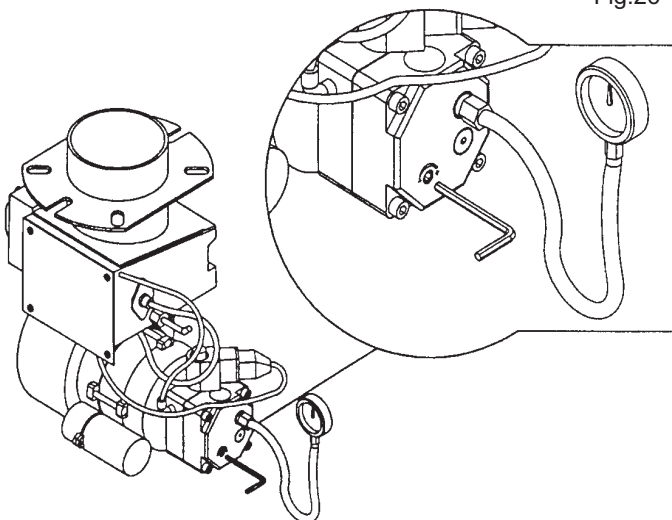

Fig.27

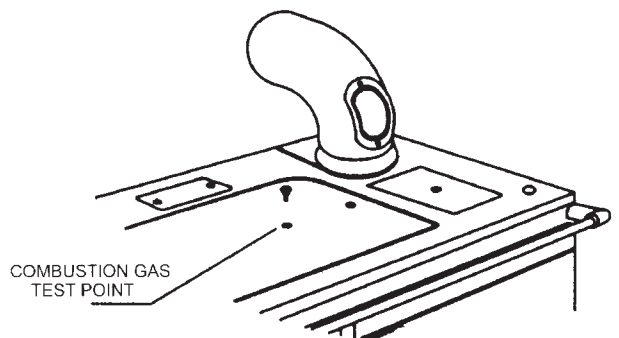
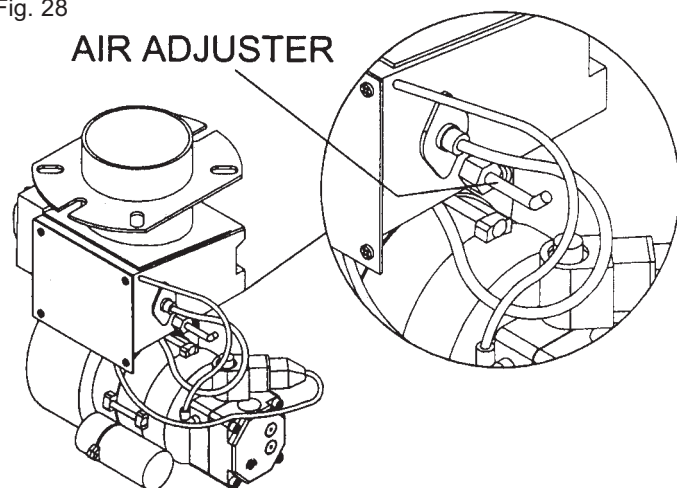

Fig. 28



11. Find the correct position of the air adjuster (See Fig. 28), which gives the highest possible reading in the range 10.4% - 11.2%, without exceeding a smoke No. 0-1 (Bacharach Scale).
12. Check the oil supply for leaks from storage tanks via oil filter.
13. Check if complete system is working correctly.
14. Make sure specified clearances are adhered to.
15. Check flue joints are sealed correctly and that no escapes are present.
16. After withdrawing the mains cable tighten the anti-tug gland located at the left side of the cooker base level.
17. Refer to the Operation Instructions Manual for correct operation of the appliance and familiarise the occupants on the correct method of operating the appliance.

LEAVE ALL DOCUMENTS WITH THE END USER

FUNCTION

Normal Start

Pre-ignition and pre-purging, after 7 seconds oil released, and the burner operates, if the flame forms within the safety time of 10 seconds.

Post ignition after oil release:

LOA 24 - 10 seconds.

False light at start

If oil is released and no flame is established the control will cut out within the safety time of: 10 seconds.

Flame failure in operation

In the event of flame failure in operation the oil supply is cut off and the control restarts the burner as described under the heading "Normal Start". On flame failure, immediately after burner start, the control will initiate re-ignition.

Flame monitoring

The flame is monitored by a photocell unit. Note: In accordance with the latest ISO and DIN standards, type LOA activates the safety relay if the photocell unit is exposed to light in the pre-purging period.

Control of flame signal

The photocell current is measured with a d.c. ammeter (moving coil instrument) which is connected in series with the photocell unit. Min current for flame indication: 35 μ A.

GENERAL MAINTENANCE

It is important that the user is familiar with their cooker and that they ensure regular checks and maintenance which can limit unnecessary breakdowns.

SERVICING

To ensure continued efficient and safe operation of the appliance it is recommended that it is checked and serviced as necessary at regular intervals. The frequency of servicing will depend upon the particular installation and usage, but in general once a year should be adequate.

INSTALLATION CHECK LIST

Flue System



The relevant guidelines must be adhered to for the relevant flue system A, B & C:

A. Use of an Existing Chimney

1. If connecting to an existing chimney, the appliance should be connected to a 125mm (5") diameter continuous, rigid or flexible flue pipe that terminates in excess of 0.6 metres from the nearest point on the roof measured vertically, and in excess of 2.3 metres measured horizontally.
2. Minimum Flue Height of 4.6 metres (15 feet).
3. Any horizontal flue sections should not exceed 300mm (12").
4. The chimney serving this appliance should not serve any other appliance.
5. A suitable flue terminal should be fitted at the flue termination point.
6. Closure-clamping plates should be used to seal the top & bottom of the chimney.
7. If the flue passes through a combustible wall, a twin wall insulated connector must be used and come flush to the external surface of the wall.
8. The flue should be capable of producing a continuous draught of between 0.04" to 0.06" w.g.

B. Use of an External Flue

1. If using an external flue, the appliance should be connected to a 125mm (5") diameter rigid insulated flue pipe suitable for oil-fired appliances that terminates in excess of 0.6 metres from the nearest point on the roof measured vertically and in excess of 2.3 metres measured horizontally.
2. Minimum Flue Height of 4.6 metres (15 feet).
3. Any horizontal flue sections should not exceed 300mm (12").
4. The chimney serving this appliance should not serve any other appliance.
5. A suitable flue terminal should be fitted at the flue termination point.
6. The flue should be capable of producing a continuous draught of between 0.04" to 0.06" w.g.

C. Use of a Stanley Fan Flue

1. The flue terminal should be positioned to adhere to the minimum clearances to external obstructions as described in the Position of Fan Flue Terminals for Oil Fired Cookers on the Brandon Fan Flue manual.
2. The exhaust point of the flue should be orientated to avoid any potential recirculation of flue gases through the air vents.

Location

1. The cooker should be installed on a non-combustible material capable of supporting the weight of the unit.
2. The cooker should be positioned so as to maintain a 10mm gap between the cooker and the adjacent kitchen units.

Plumbing (DHW Models Only)

1. A three bar safety valve must be fitted to the primary flow pipe adjacent to the boiler connection on the stove.
2. The cooker must be connected to a fully pumped system using 28mm flow & return supply pipes, with the pump controlled by a pipe stat fitted to the flow pipe as close as possible to the cooker.
3. If the cooker is going to be used for long cooking periods on a regular basis, an indirect system should be used so as to allow the fitting of a heat sink radiator in order to off-load the excess hot water generated.

Ventilation & Combustion Air Requirements

1. The room in which the appliance is located should have an air vent of adequate size to support correct combustion when all air-using appliances are working at full capacity (See Ventilation & Combustion Air Requirement Section for specific details).

Oil Supply

1. The oil supply tank should be fitted with an isolating valve and filter.
2. The stove should be connected to a supply line with a minimum internal diameter of 10mm ($\frac{3}{8}$ ") and must be fitted with a remote acting fire valve.
3. If a single pipe oil supply system is used, a minimum head of oil of 1 meter must be maintained (see Fuel Installation section).

DOOR HANDLE REPLACEMENT INSTRUCTIONS

Tools required

- * Small Philips head screw driver
- * 2 mm allen key
- * Flat head screwdriver.

Step 1

Remove the 2 round head screws and the retaining clip on the back of the door while ensuring the spring behind does not spring out. See Fig. A & B.

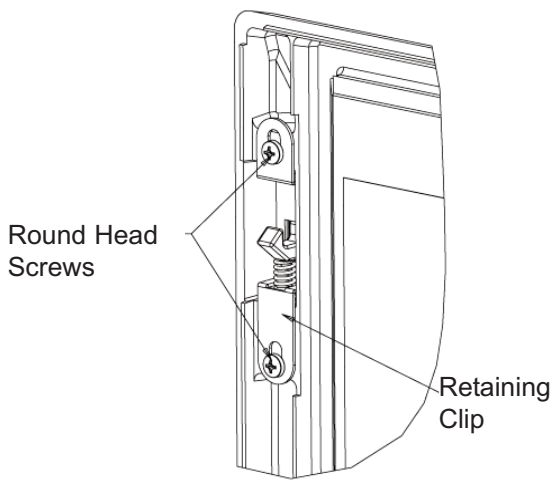
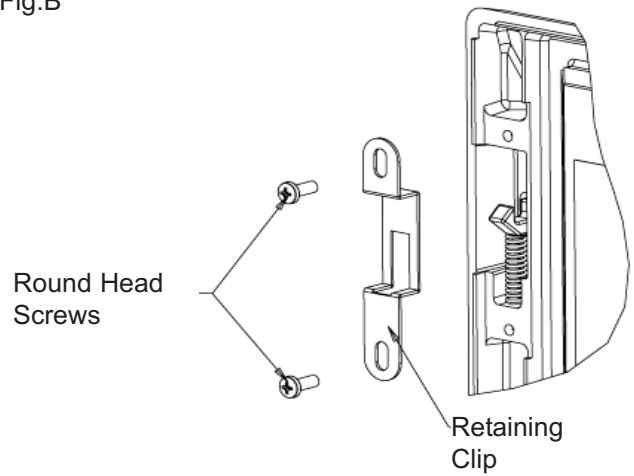

Fig.A

Fig.B



Step 2

Remove the compression spring and screw. See Fig. C.

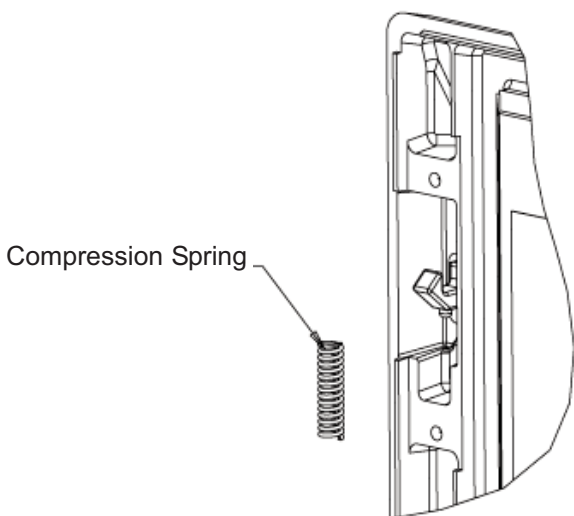

Fig.C

Step 3

From the front face loosen the grub screw on the underside of the latch using the 2mm allen key. See Fig.D.

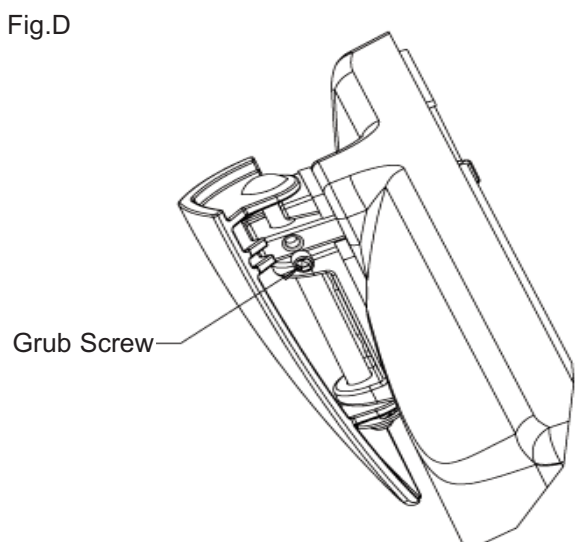
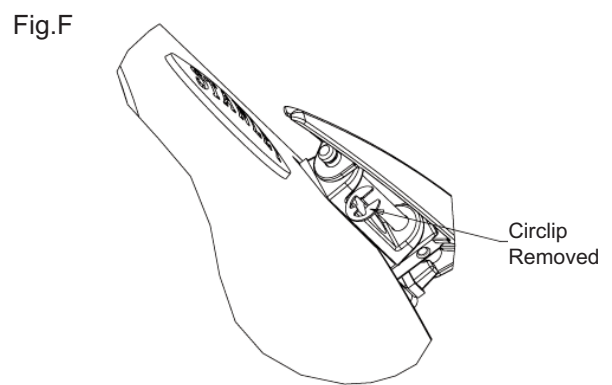
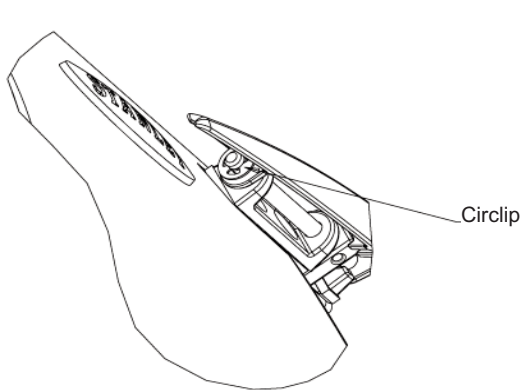

Fig.D

Step 4

Using a small flat head screwdriver remove the circlip from the end of the door handle axle. See Fig.E & F.



Step 5

While holding the handle pull out the door handle axle. See Fig.G & H.

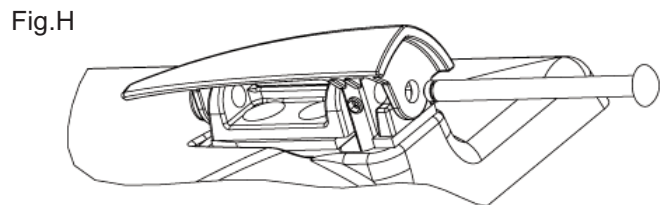
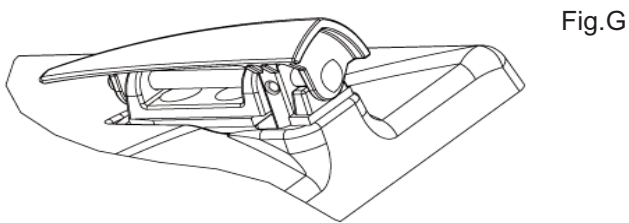

Step 6

Replace the Nylon handle with the chromed handle and reverse the above procedure - Step 5 - 1. See Fig. I

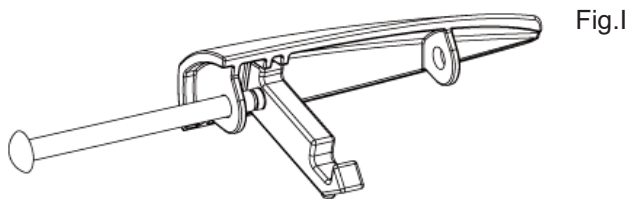



STANLEY OIL COOKER WARRANTY

CONDITIONS OF WARRANTY

Your Stanley Oil Cooker is guaranteed against any part that fails (under normal operating conditions) within twelve months from the date of installation of the appliance. If the unit is not installed within six months of date of purchase, the warranty will commence six months from the date of purchase. The warranty is given only to the original consumer/purchaser only and is non-transferable. The appliance must be installed by a suitable qualified person and installed as per the requirements of the manual. Failure to comply with the installation requirements will void your warranty. Waterford Stanley reserve the right to replace any part due to manufacturing defect that fails within the warranty period under the terms of the warranty. All Oil appliances must be commissioned by an authorised Stanley Engineer to validate your warranty and same should be booked with the Waterford Stanley Service Department no later than 2 weeks after the installation has been completed. The unit must be used for normal domestic purposes only and in accordance with manufacturer's operation instructions.

LIMITS OF LIABILITY

The warranty does not cover:

- * Special, incidental or consequential damages, injury to persons or Property, or any other consequential loss.
- * Any issue caused by negligence, misuse, abuse or circumstances beyond Waterford Stanley's control.
- * Any issue with wear and tear, modification, alteration, or servicing by anyone other than an authorized service engineer.
- * Installation and operational related problems such as draught related issues external to the cooker, inadequate venting or ventilation, excessive flue offsets, negative air pressure caused by insufficient burning of improper fuel.
- * Damage caused to the unit while in transit.
- * Enamel discolouration due to over firing, enamel damage caused by impact, damage to baffles caused by over firing and fading of surface finish on casting.
- * Rust on cast iron parts unless reported prior to unit being installed.
- * Aesthetic damage, rust & missing parts on units purchased off display.

Note: Adequate clearance must be maintained around the appliance to ensure the ease of part removal in the possible event of their damage/failure. Waterford Stanley are not responsible for any costs incurred in the removal of items installed in the vicinity of the appliance that have to be moved to facilitate a part replacement.

All warranty claims must be reported to the Waterford Stanley Service Department and must be submitted with the product serial number (located on the front casting), date of purchase, proof of purchase (if requested) and details of the specific nature of the problem.

Manufactured by
Waterford Stanley Ltd.,
Unit 401-403, IDA Industrial Estate, Cork Road,
Waterford, Ireland.
Tel: (051) 302300 Fax (051) 302315

